









































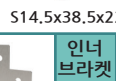
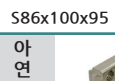



































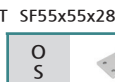







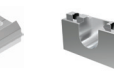





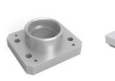

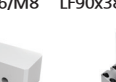









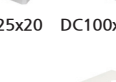
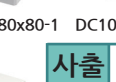
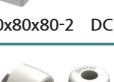

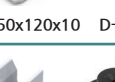
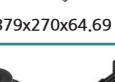



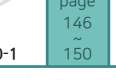

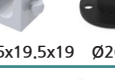







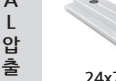
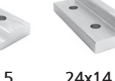

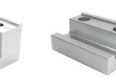
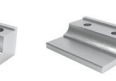

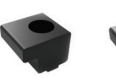
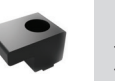









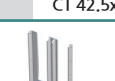
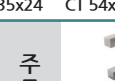

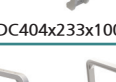
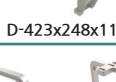
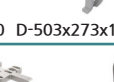

# BRACKET

STEEL page 096 ~ 113	직각조립용	 표준 20  표준 30  표준 40  표준 60  표준 80  표준 120  F SERIES  LG40  LG50  LG80  LD SERIES  HS SERIES  CF SERIES  SL SERIES  S25x23x50  TAP 고정형  S34x44x50  S39x39x75  S40x35x50  S70x35  S73x39x32-403W  S73X39X68-802W  S75x75x104  S14.5x38.5x22  S86x100x95  S ETC SERIES  태양광용  각도용  직각용
		 I형  □형  L형  T형  +형  인너 브라켓 page 113 ~ 114  야연 캐스팅 D30x22.40x35  프레스 G(직각형)  G.O(각도형)
알루미늄 page 115 ~ 145	직각조립용	 G20용  G30용  G30x60  G40용  G40x80  G45x45  G45x90  G30x55  G60x55  G60x60  G40x70,40x75용  G7575,8075,8080용  G90용  GS75x32-12T  GS75x72-12T  GS75x88x12T  GS75x110  SF30x30x21  SF35x30  SF35x60x10T
		 SF40x23  SF40x65-15T  SF40x650  SF52x38x28T  SF55x55x28  SF60x74x9T  SF60x80xD28  SF65x34x10T  SF75x75x38  SF100x100x78  SF80x80-D28  SF80x80x28  SF100x100x78  SF100x100x38  OS 시리즈 OS Series  OS200x140x12T  기타 센서브라켓  RCBK 30  RCBK 40  YKAJ M6/M8
클램프 page 150 ~ 159	A L 캐스팅	 YKSH M6/M8  LF90x38x13T  LF70x40x13T  DC45x21.5x16T  GEAR BOX  CLAMP BLOCK  DC34x20x22.5  DC40x72x25  DC50x72x22  DC60x70x29  DC60x40x10  DC60x25x20  DC100x80x80-1  DC100x80x80-2  DC100x36x28  D137x68x20  DC250x120x10  D-379x270x64.69  D90-1L  D100-1  DCJ30SV  MA90-1-L  MA110-1  사출 page 146 ~ 150 M-CS-D30  M-CS-50x30x30  AT65x20  P19.5x19.5x19  Ø26x9  45x60x185  54x14.5x8.5  M64x45x30  M137x68x20
		 AL 압출 24x7.5  24x14.5  43x15  45x36  45x36-1  49x42  49x42-1  54x32  60x21.5xL  98x42  사출 P15x17x13  P15x21x13  주물 CT 42.5x35x24  CT 54x50x38
OHC V page 159 ~ 168	캐스팅	 DC404x233x100  D-423x248x110  D-503x273x110  DC400x405x35  D-SHELF-860  D-SHELF-528  D-SHELF-332  주물 CT 115x194.5x52  C-115x167x52  C392x191x90  CT393x253.5x70  CT393x216x150  C105x97.5x60  C105x122x60  C130x121x69  C130x144x69  C140x87x85  C180x130x110  C-100x132x44
		 BASE  BLOCK  BRACKET  C PLATE  HINGE L-R  PLATE  SHAFT  WASHER  TB-M16x100
2차 전지용 page 174 ~ 176		 REFLECTOR PLATE 43x23x35  REFLECTOR PLATE 61x41x35  REFLECTOR PLATE 64x61  SENSOR BRACKET 53x46x36  SENSOR BRACKET 53x46x38

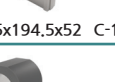

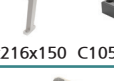

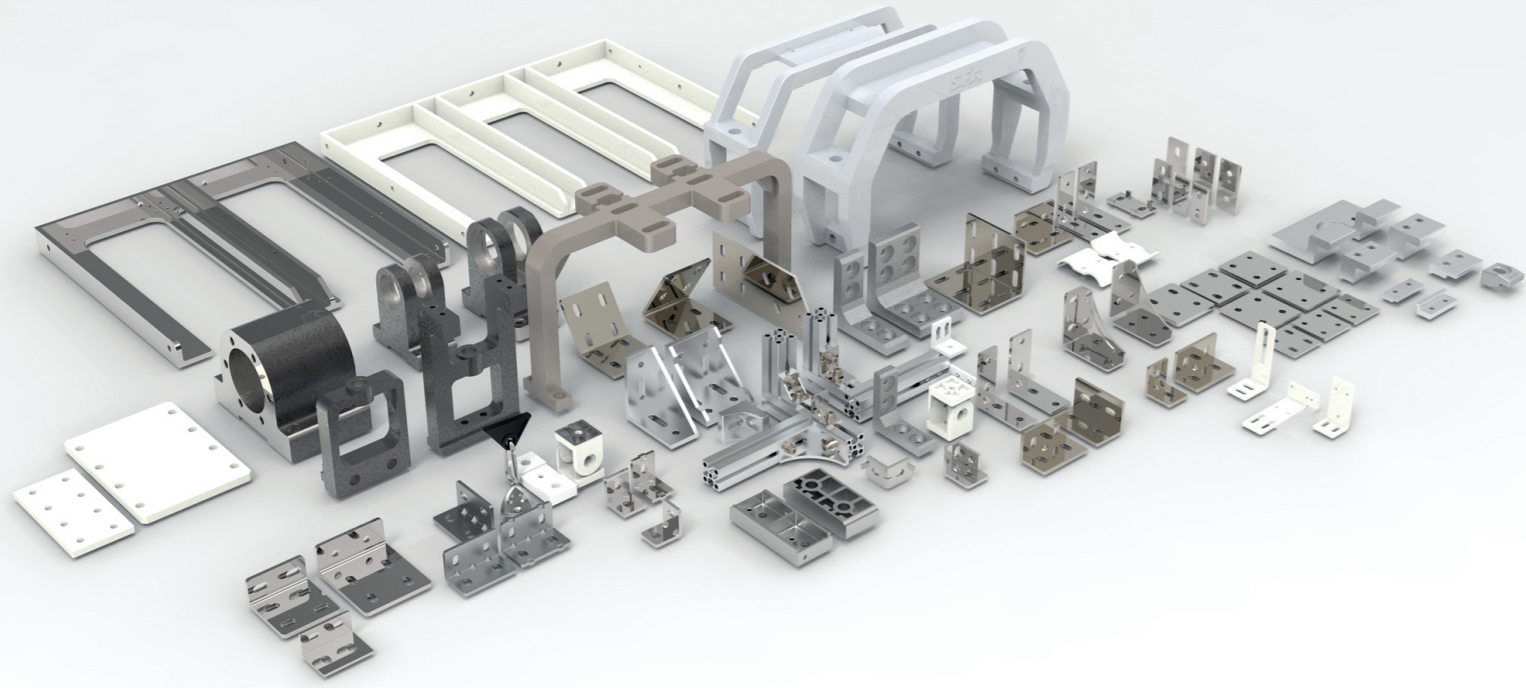
# Aluminum Profile Connection Bracket

Yeung Kwang Tech

최고의 제품을 최적의 가격으로  
공급 해 드립니다.

브라켓은 흔들림에 대한 보호, 신속하고 정확한 조립 가능합니다. 프로파일 홈 또는 플레이트에 조립, 직각뿐 아니라 각도와 부품 고정용부터 서포터브라켓, PC복합판에 이르기까지 크기와 모양이 다양해서 조립상황에 맞게 사용할수 있습니다. 강도와 인장 하중 피막처리 시험 인증서를 공개 하고있으며 품질을 엄격하게 관리하고 있습니다.

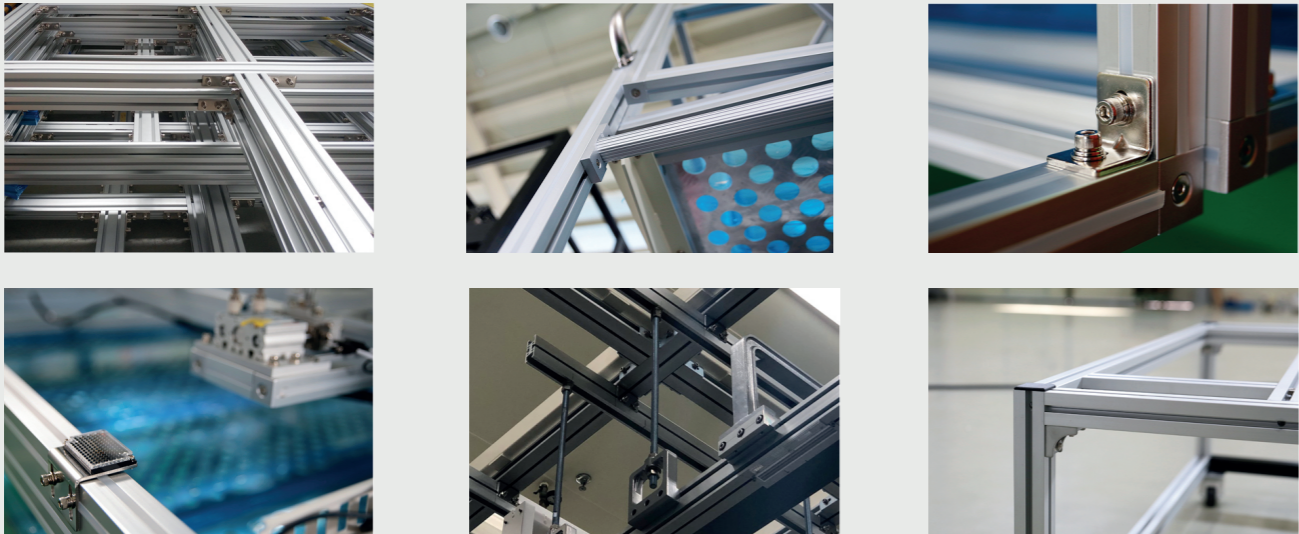
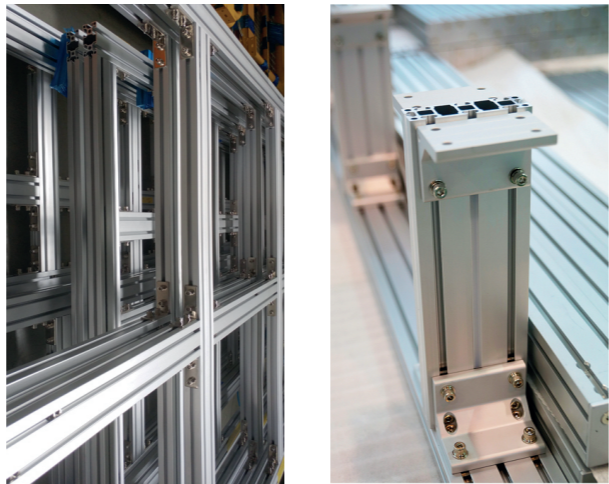

YKBK-S7035  
영광테크 스틸 70x35 브라켓

YKBK-AGS 75 32  
영광테크 알루미늄 GS시리즈 75x32 브라켓

2d, 3d 및 상세한 내용은 홈페이지(www.yktec.co.kr) 참조



## Bracket Ordering Code

EXAMPLE

YKBK - AGS 75 32 SAE

후처리 ( / Post-Processing)

규격(Profile)

재질(Material / Type Series)

Yeung Kwang Bracket

EXAMPLE = 영광테크 알루미늄 브라켓 75x32 규격 표면처리 Sliver



### YKBK-S 표준20 SERIES

STEEL BRACKET-직각조립용

Material SPHC

Surface Processing NI(니켈), ZN(아연)

Application 강한 체결력을 요하는 작업에 사용



Code : YKBK-SG2015  
Code : YKBK-SG2035



Code : YKBK-SG4035  
Code : YKBK-SG4075

### YKBK-S 표준40 Series

STEEL BRACKET-직각조립용

Material SPHC

Surface Processing NI(니켈), EL(무전해니켈)

Application 강한 체결력을 요하는 작업에 사용

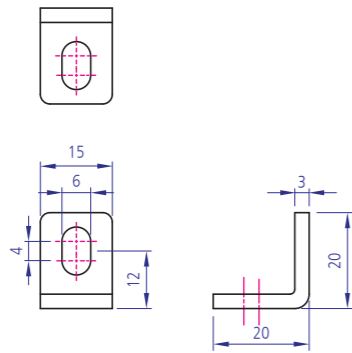
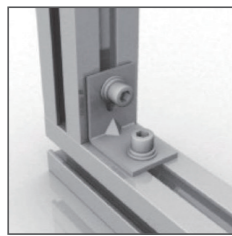

YKBK-S G20\*15

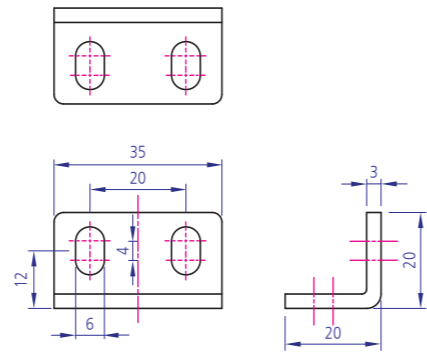

YKBK-S G20\*35

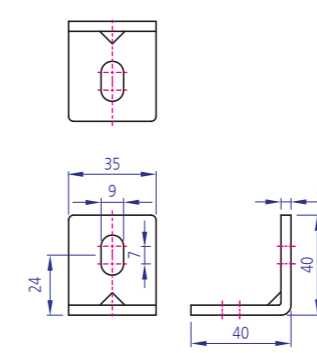
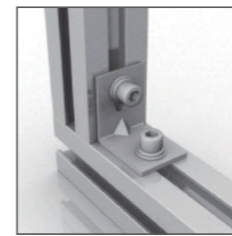

YKBK-S G40\*35

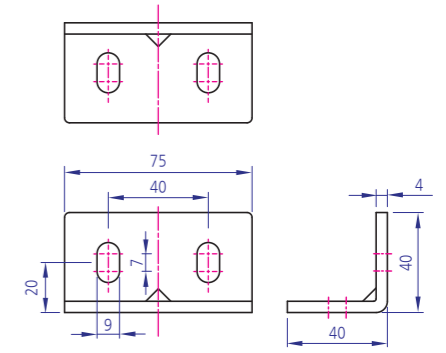

YKBK-S G40\*75

### YKBK-S 표준30 SERIES

STEEL BRACKET-직각조립용

Material SPHC

Surface Processing NI(니켈), ZN(아연)

Application 강한 체결력을 요하는 작업에 사용



### YKBK-S 표준40 SERIES

STEEL BRACKET-직각조립용

Material SPHC

Surface Processing NI(니켈), ZN(아연)

Application 강한 체결력을 요하는 작업에 사용

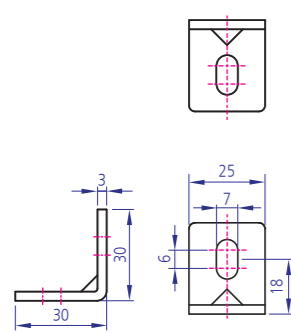

YKBK-S G30\*25  
Code : YKBK-SG3025

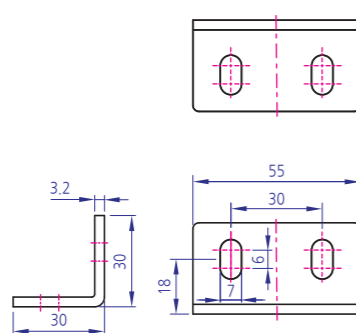

YKBK-S G30\*55  
Code : YKBK-SG3055

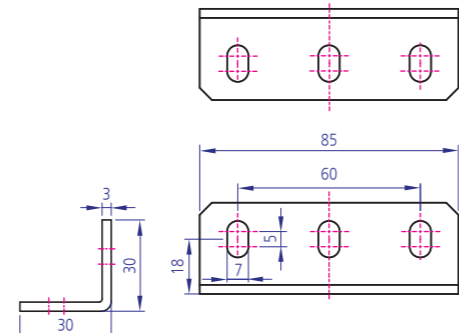

YKBK-S G30\*85  
Code : YKBK-SG3085

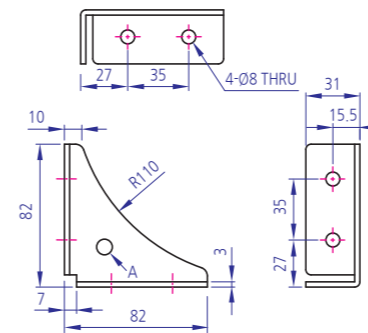

YKBK-S G40\*80(HOLE)  
Code : YKBK-SGT4080H

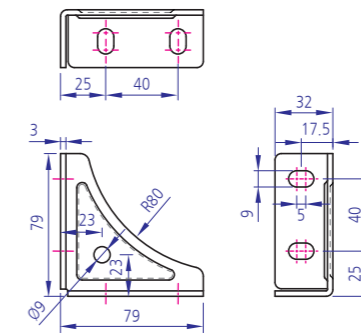

YKBK-S G40\*80(장공)  
Code : YKBK-SGT4080L

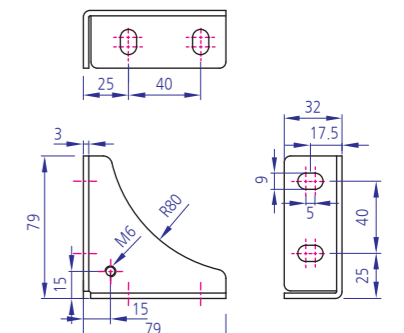

YKBK-S G40\*80(장공) T40\*80(P15\*15)  
Code : YKBK-SGT4080A

### YKBK-S 표준60 SERIES

STEEL BRACKET-직각조립용

Material SPHC

Surface Processing NI(니켈), EL(무전해니켈)

Application 강한 체결력을 요하는 작업에 사용

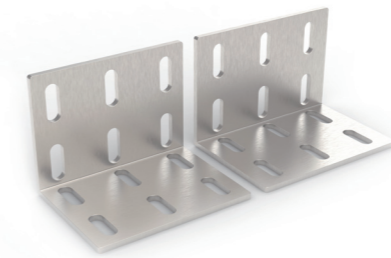

### YKBK-S 표준120 Series

STEEL BRACKET-직각조립용

Material SPHC

Surface Processing NI(니켈), ZN(아연)

Application 강한 체결력을 요하는 작업에 사용

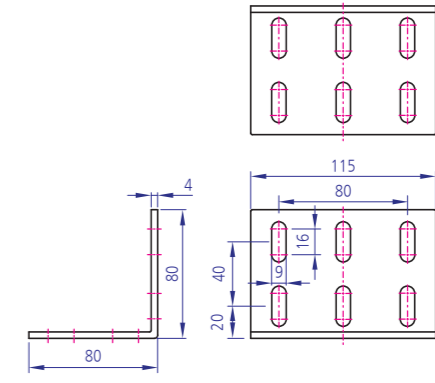
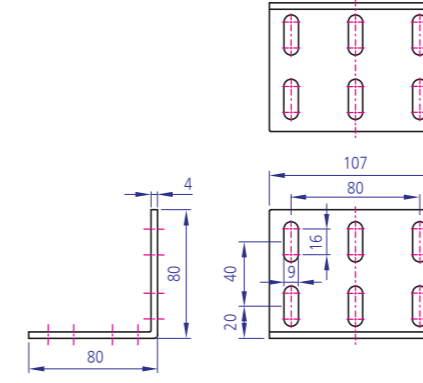
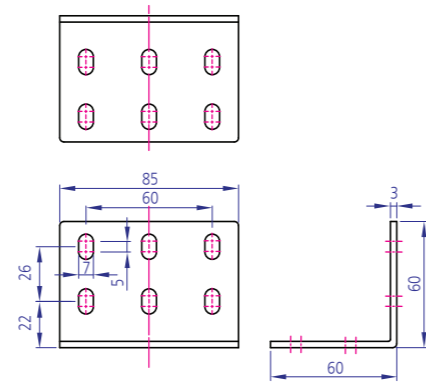
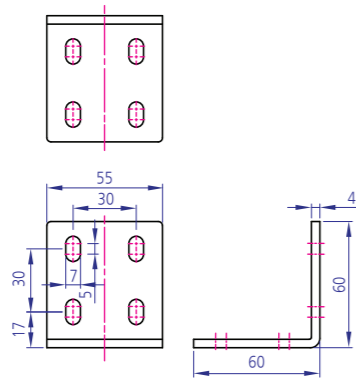
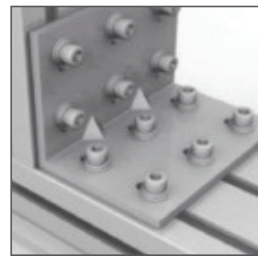

### YKBK-S 표준80 SERIES

STEEL BRACKET-직각조립용

Material SPHC

Surface Processing NI(니켈), ZN(아연)

Application 강한 체결력을 요하는 작업에 사용

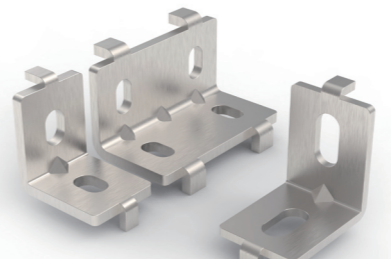

### YKBK-S F SERIES

STEEL BRACKET-직각조립용

Material SPHC

Surface Processing NI(니켈), ZN(아연)

Application 강한 체결력을 요하는 작업에 사용, 결합시 이탈방지

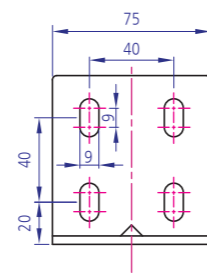
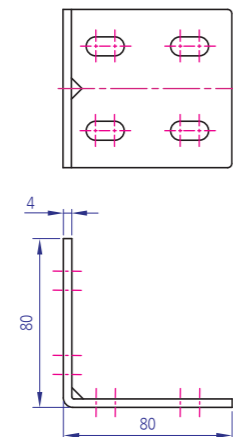



### YKBK-S LG40 SERIES

STEEL BRACKET-직각조립용

Material SPHC

Surface Processing NI(니켈), EL(무전해니켈)

Application 강한 체결력을 요하는 작업에 사용

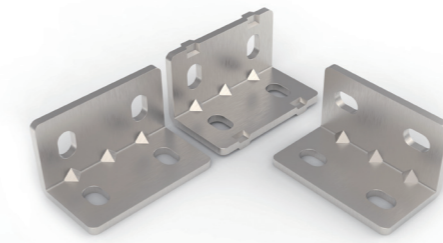
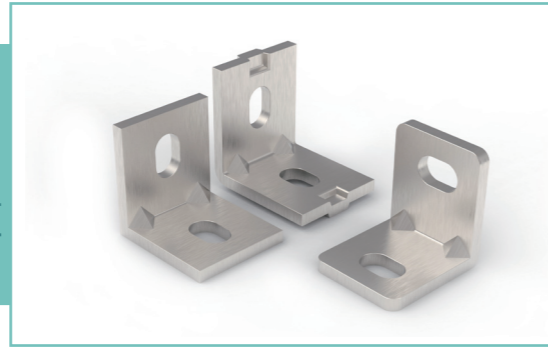

### YKBK-S LG80 SERIES

STEEL BRACKET-직각조립용

Material SPHC

Surface Processing NI(니켈), EL(무전해니켈)

Application 강한 체결력을 요하는 작업에 사용

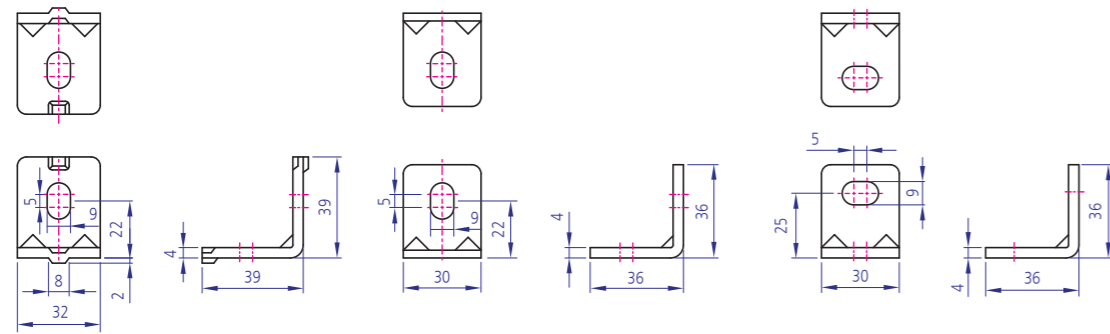

YKBK-S LG401  
Code : YKBK-SLG401

YKBK-S LG402  
Code : YKBK-SLG402

YKBK-S LG403  
Code : YKBK-SLG403

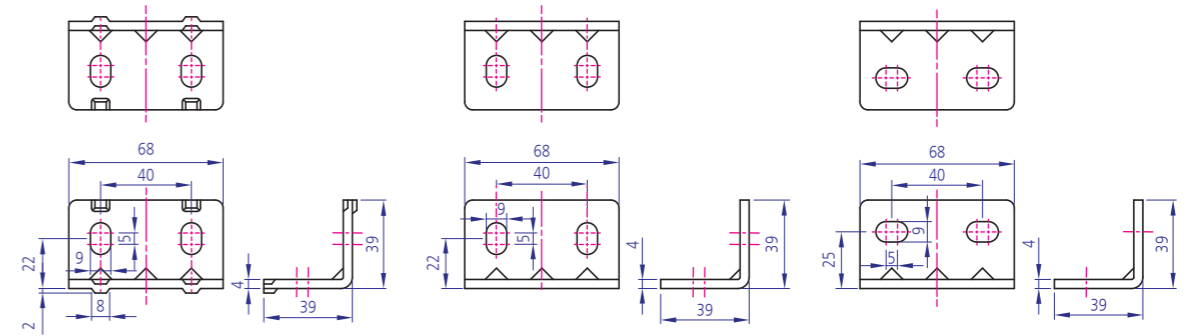

YKBK-S LG801  
Code : YKBK-SLG801

YKBK-S LG802  
Code : YKBK-SLG802

YKBK-S LG803  
Code : YKBK-SLG803

### YKBK-S LG50 SERIES

STEEL BRACKET-직각조립용

Material SPHC

Surface Processing NI(니켈), EL(무전해니켈)

Application 강한 체결력을 요하는 작업에 사용

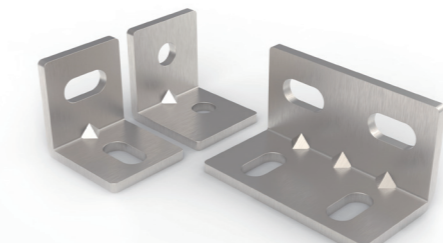

### YKBK-S LD SERIES

STEEL BRACKET-직각조립용

Material SPHC

Surface Processing NI(니켈), IVORY(아이보리)

Application 강한 체결력을 요하는 작업에 사용

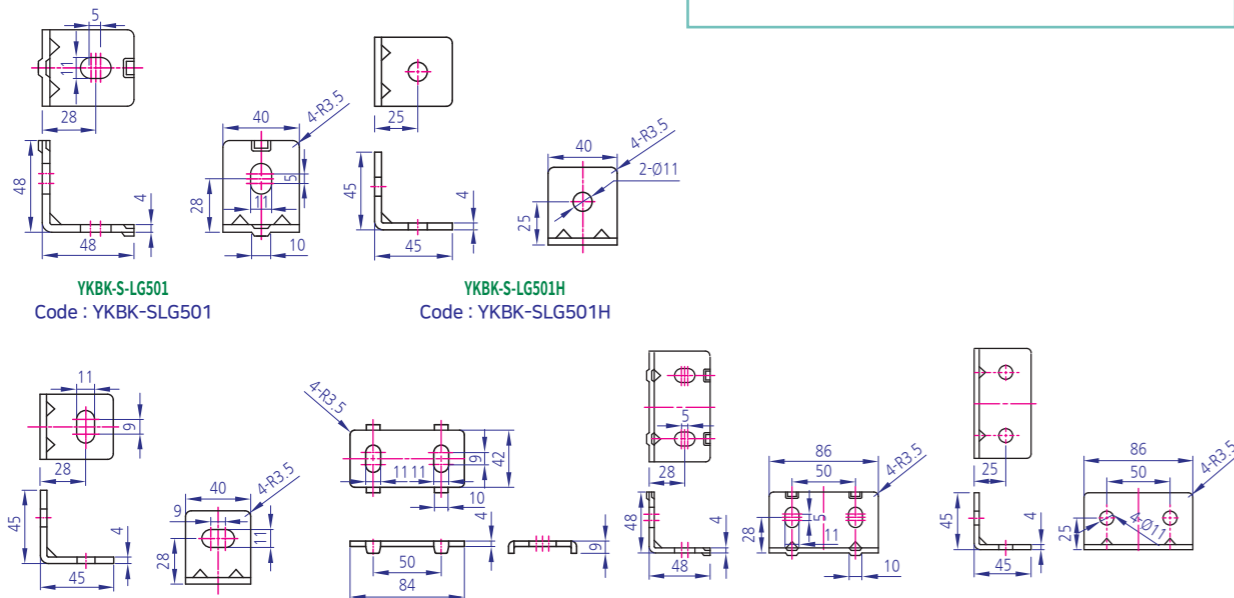

YKBK-S LG501  
Code : YKBK-SLG501

YKBK-S LG501H  
Code : YKBK-SLG501H

YKBK-S LG503  
Code : YKBK-SLG503

YKBK-S LG504  
Code : YKBK-SLG504

YKBK-S LG1001  
Code : YKBK-SLG1001

YKBK-S LG1001H  
Code : YKBK-SLG1001H

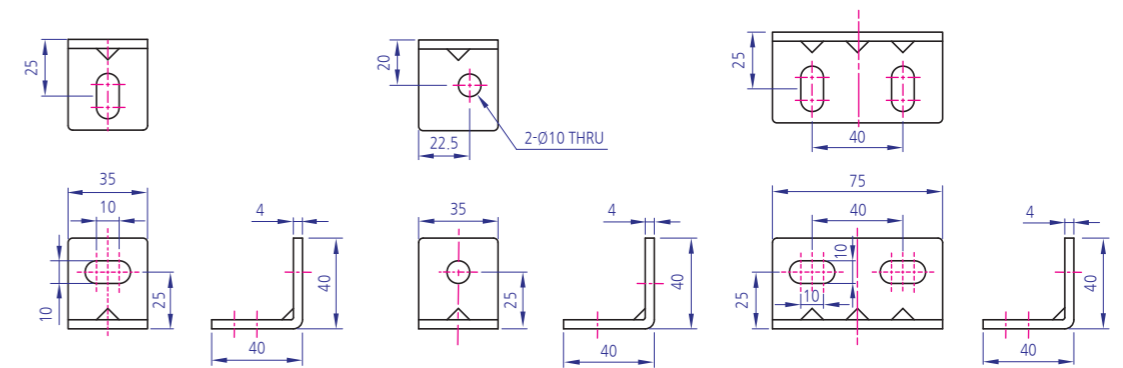

YKBK-S LD40\*35(SLOT10)  
Code : YKBK-SLD4035

YKBK-S LD40\*35(HOLE)

YKBK-S LD40\*75(SLOT10)  
Code : YKBK-SLD4075

**YKBK-S HS SERIES**

STEEL BRACKET-직각조립용

Material SPHC

Surface Processing NI(니켈), EL(무전해니켈)

Application 강한 체결력을 요하는 작업에 사용

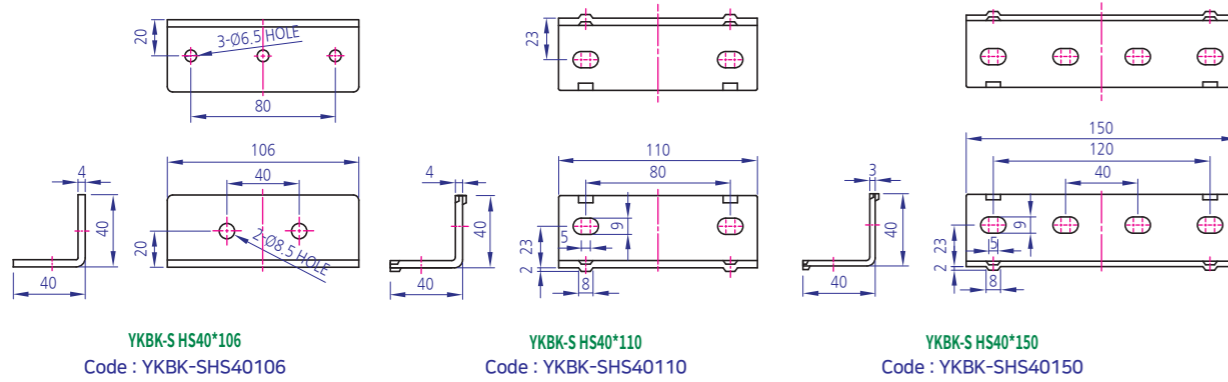

YKBK-S HS40\*106  
Code : YKBK-SHS40106

YKBK-S HS40\*110  
Code : YKBK-SHS40110

YKBK-S HS40\*150  
Code : YKBK-SHS40150

**YKBK-S CF SERIES**

STEEL BRACKET-직각조립용

Material SPHC

Surface Processing NI(니켈), ZN(아연)

Application 강한 체결력을 요하는 작업에 사용

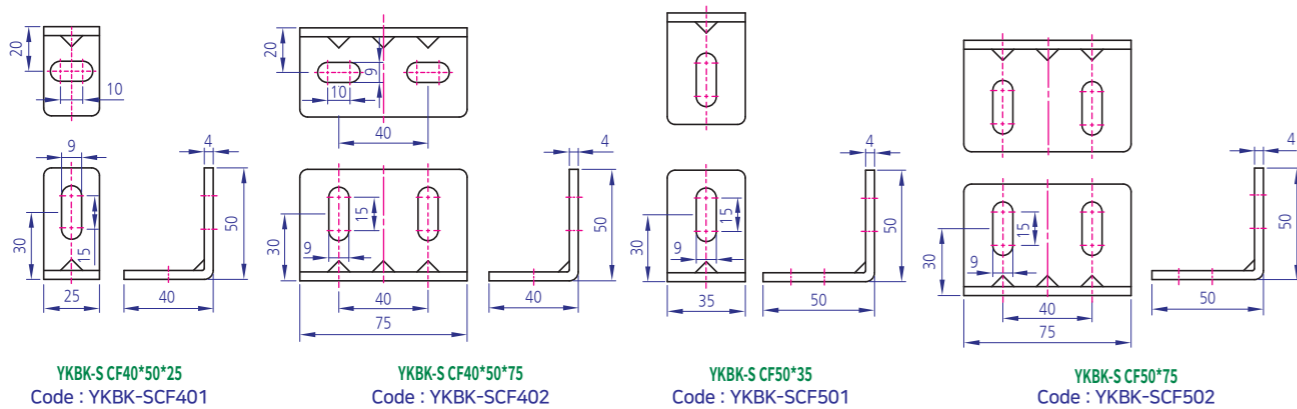

YKBK-S CF40\*50\*25  
Code : YKBK-SCF401

YKBK-S CF40\*50\*75  
Code : YKBK-SCF402

YKBK-S CF50\*35  
Code : YKBK-SCF501

YKBK-S CF50\*75  
Code : YKBK-SCF502

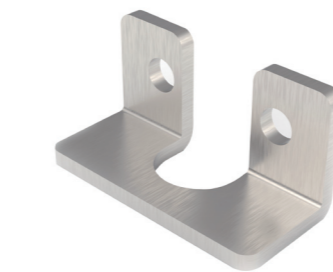

Code : YKBK-S2523

**YKBK-S-25x23x50**

STEEL BRACKET-직각조립용

Material SPHC

Surface Processing NI(니켈), EL(무전해니켈)

Application 강한 체결력을 요하는 작업에 사용

참고 행거사프트 조립용

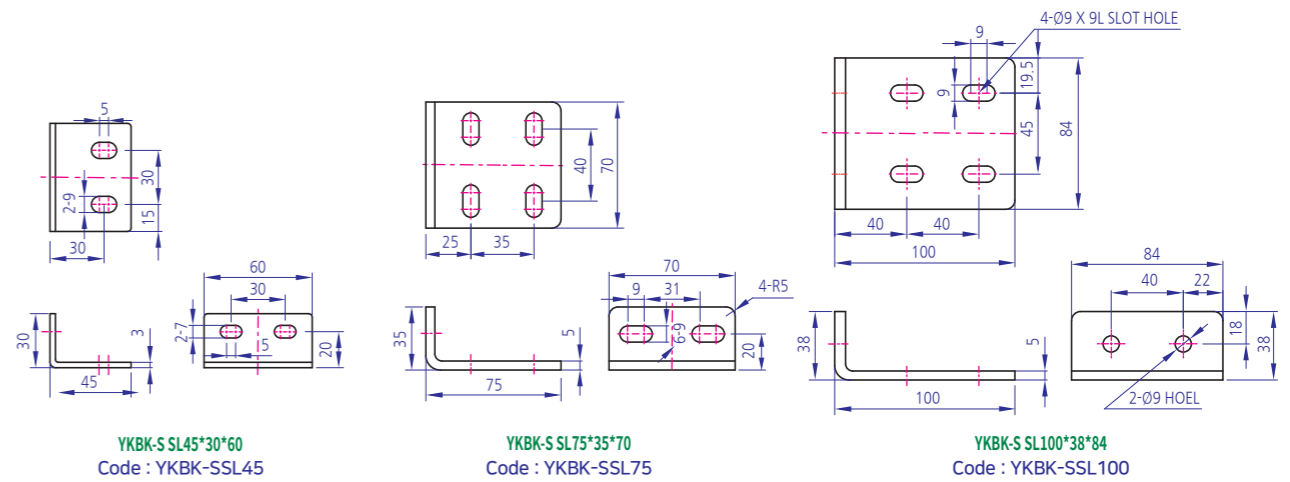
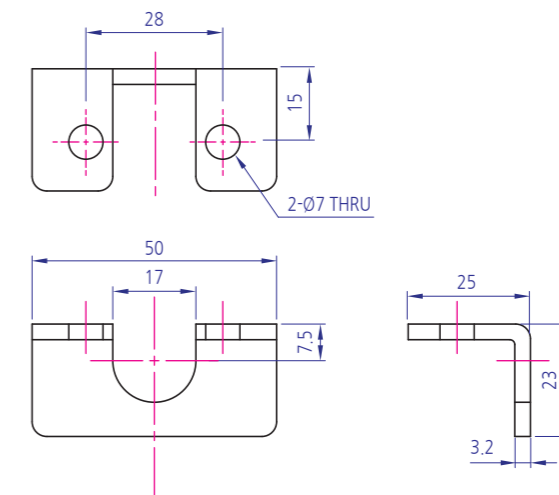

YKBK-S SL45\*30\*60  
Code : YKBK-SSL45

YKBK-S SL75\*35\*70  
Code : YKBK-SSL75

YKBK-S SL100\*38\*84  
Code : YKBK-SSL100



**YKBK-S TAP고정형 SERIES**  
STEEL BRACKET-직각조립용

**Material** SPHC  
**Surface Processing** NI(니켈)  
**Application** BRACKET를 이용하여 직각조립과 동시에 아크릴판 등을 고정하는 용도로 사용

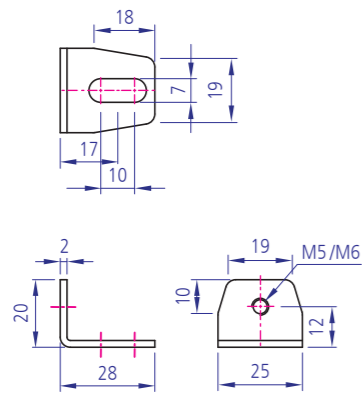

**YKBK-S T28\*25(M5,M6)**  
Code : YKBK-ST2825

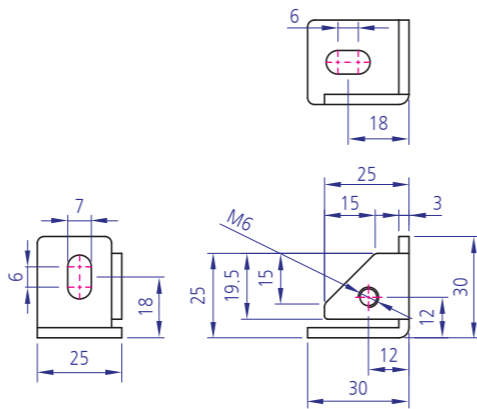

**YKBK-S T30\*25(M6)**  
Code : YKBK-ST3025A

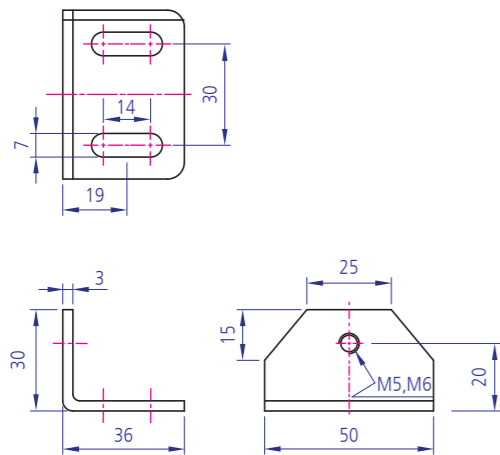

**YKBK-S T30\*50(M5,M6)**  
Code : YKBK-ST3050

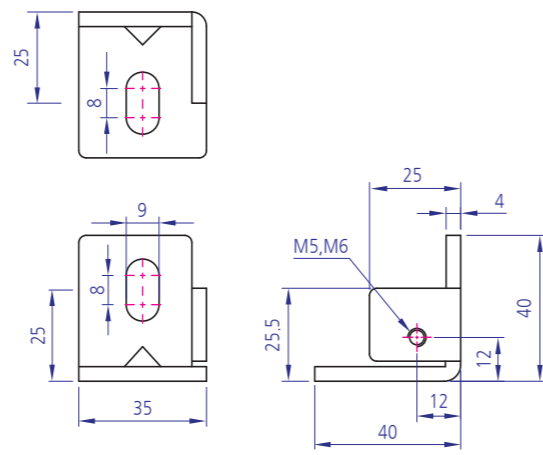

**YKBK-S T40\*35(M5,M6)**  
Code : YKBK-ST4035



Code : YKBK-S3444

**YKBK-S34x44x50**  
STEEL BRACKET-직각조립용

**Material** SPHC  
**Surface Processing** IVORY도장  
**Application** 강한 체결력을 요하는 작업에 사용  
참고 발주시 SET(2EA)기준 발주 요망

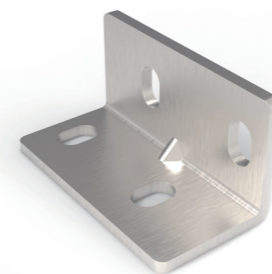
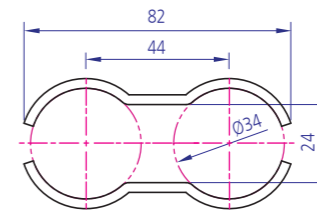
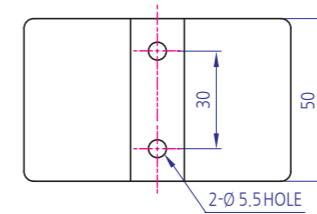

Code : YKBK-S3975

**YKBK-S-39x75-4T**  
STEEL BRACKET-직각조립용

**Material** SPHC  
**Surface Processing** NI(니켈), EL(무전해니켈)  
**Application** 강한 체결력을 요하는 작업에 사용

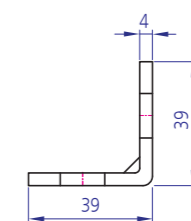
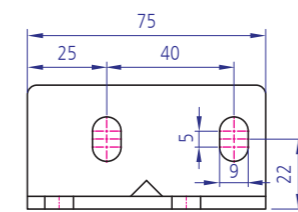
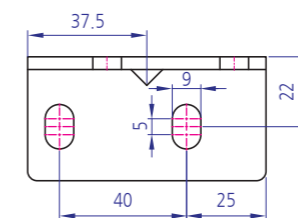

Roller  
Bearing Holder  
Motor Base  
Bracket  
Multi Block  
Joint  
Hinge  
Magnet  
Handle  
Foot Base  
방진구  
Levelling Foot  
Cover  
End Cap  
Bolt  
Nut  
Washer  
Special  
Profile  
Caster

**YKBK-S-40x35x50**  
STEEL BRACKET-직각조립용

Material SPHC  
Surface Processing NI(니켈), EL(무전해니켈)  
Application 강한 체결력을 요하는 작업에 사용



Code : YKBK-S4035

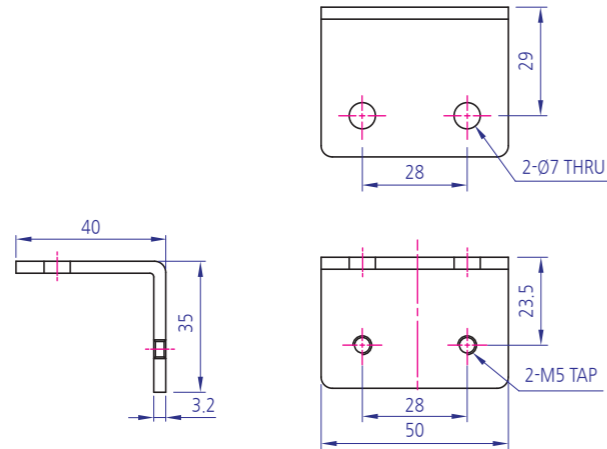

**YKBK-S-70x35**  
STEEL BRACKET-직각조립용

Material SPHC  
Surface Processing NI(니켈), EL(무전해니켈)  
Application 강한 체결력을 요하는 작업에 사용  
참고 행거사프트 조립용



Code : YKBK-S7035

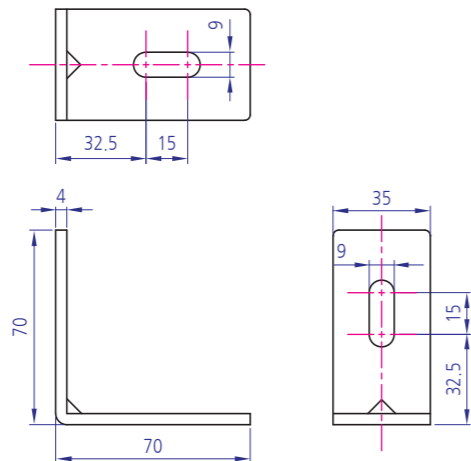

Code : YKBK-SLG403W

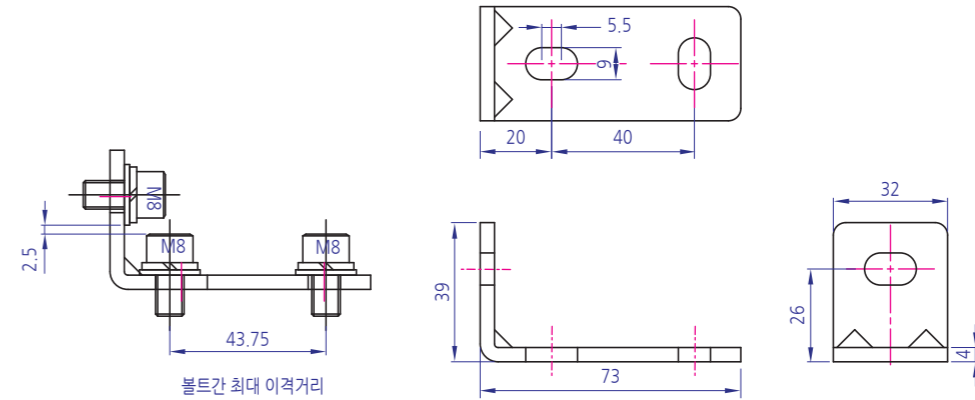

**YKBK-S73x39x32\_403w**  
STEEL BRACKET-직각조립용

Material SPHC  
Surface Processing NI(니켈), EL(무전해니켈)  
Application 강한 체결력을 요하는 작업에 사용

**YKBK-S73x39x68\_802w**  
STEEL BRACKET-직각조립용

Material SPHC  
Surface Processing NI(니켈), EL(무전해니켈)  
Application 강한 체결력을 요하는 작업에 사용

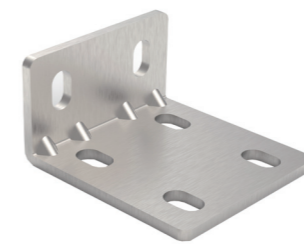

Code : YKBK-SLG802W

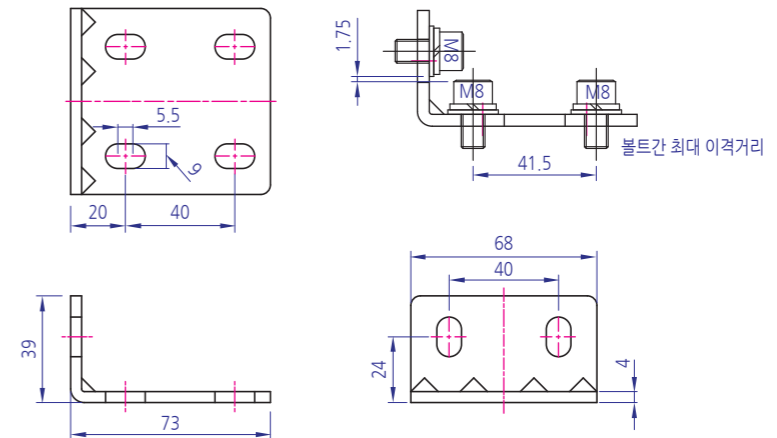



**YKBK-S-75x75x104**  
STEEL BRACKET-직각조립용

Material SPHC  
Surface Processing NI(니켈), EL(무전해니켈)  
Application 강한 체결력을 요하는 작업에 사용



Code : YKBK-S7575S

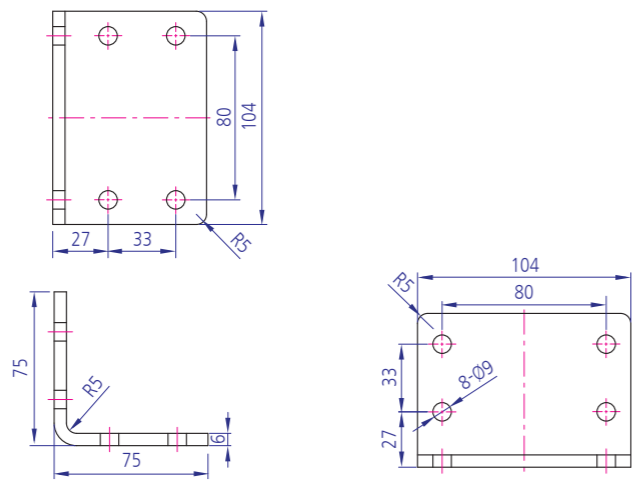

**YKBK-S14.5x38.5x22**  
STEEL BRACKET-직각조립용

Material SPHC  
Surface Processing NI(니켈), EL(무전해니켈), ZN(아연)  
Application 강한 체결력을 요하는 작업에 사용



Code : YKBK-S3822Z

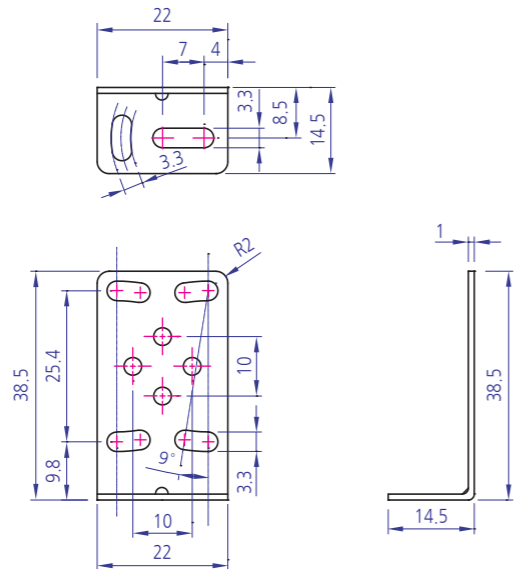

Code : YKBK-S86100

**YKBK-S86x100x95**  
STEEL BRACKET-직각조립용

Material SPHC  
Surface Processing NI(니켈), EL(무전해니켈)  
Application 강한 체결력을 요하는 작업에 사용  
참고 캐스터 부착용

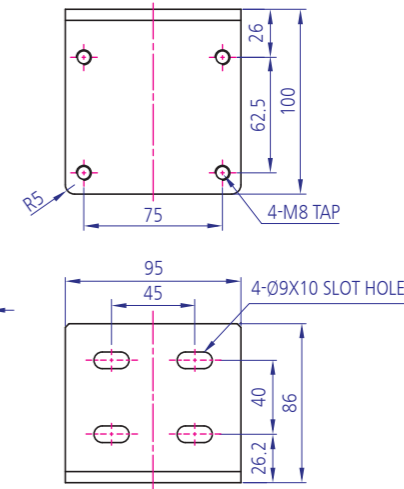

**YKBK-S ETC SERIES**  
STEEL BRACKET-직각조립용

Material SPHC  
Surface Processing NI(니켈), EL(무전해니켈), ZN(아연)  
Application 강한 체결력을 요하는 작업에 사용

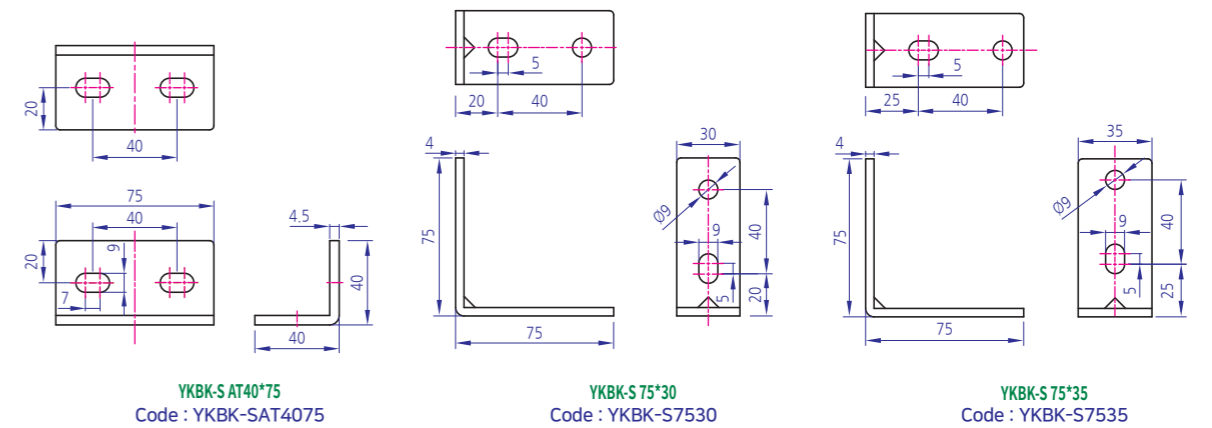

YKBK-S AT40\*75  
Code : YKBK-SAT4075

YKBK-S 75\*30  
Code : YKBK-S7530

YKBK-S 75\*35  
Code : YKBK-S7535

### YKBK-S (I형) SERIES

STEEL BRACKET-외부보강용

Material SPHC  
 Surface Processing NI(니켈), EL(무전해니켈), ZN(아연)  
 Application 강한 체결력을 요하는 작업에 사용

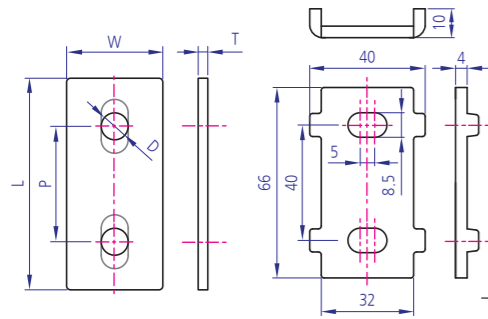

구분	규격	Code	L	W	P	D	T	Material	Plating
표준형	YKBK-S G306-I	YKBK-SGI306	55	25	30	7	2.5	SPHC	NI(니켈)
	YKBK-S G408-I	YKBK-SGI408	75	35	40	9	4		ZN(아연)
대영형	YKBK-S D306-I	YKBK-SDI306	55	25	30	7	3	SPHC	EL(무전해 니켈)
	YKBK-S D408-I	YKBK-SDI408	75	35	40	8.5	4.5		ZN(아연)
표준 장공형	YKBK-S J306-I	YKBK-SGI306L	55	25	30	Ø7*7 Slot	2.3	SPHC	EL(무전해 니켈)
	YKBK-S J408-I	YKBK-SGI408L	75	35	40	Ø9*7 Slot	3t,4t		ZN(아연)
LG형	YKBK-S LG404	YKBK-SLGI404	66	40	40	Ø8.5*5 Slot	4	SPHC	EL(무전해 니켈)
	YKBK-S LG405	YKBK-SLGI405	66	30	40	Ø9*5 Slot	4		ZN(아연)

### YKBK-S (□형) SERIES

STEEL BRACKET-외부보강용

Material SPHC  
 Surface Processing NI(니켈), ZN(아연)  
 Application 강한 체결력을 요하는 작업에 사용

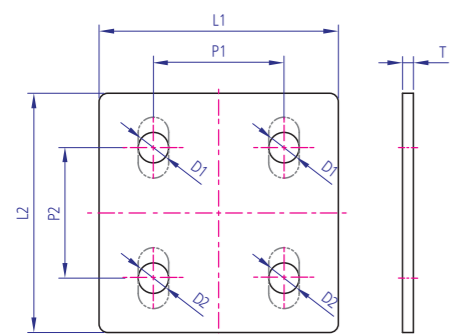
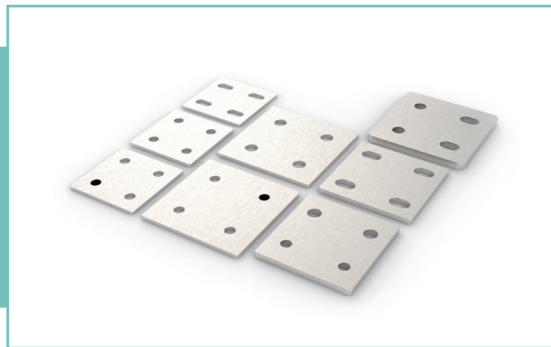

구분	규격	Code	L1	L2	P1	P2	T	D1	D2	Material	Plating
표준형	YKBK-S G306-□	YKBK-SGQ306	55	30	2.5	7	SPHC	Ø6.5*7 Slot	7	SPHC	NI(니켈)
	YKBK-S D306-□	YKBK-SDQ306	55	30	3	7					ZN(아연)
	YKBK-S J306-□	YKBK-SGQ306L	55	30	3	Ø6.5*7 Slot					7
대영형	YKBK-S G408-□	YKBK-SGQ408	76	40	3	9	SPHC	Ø8.5*5.5 Slot	9	SPHC	ZN(아연)
	YKBK-S G406-□	YKBK-SGQ406	75	40	3	7					EL(무전해 니켈)
표준 장공형	YKBK-S LG408-□	YKBK-SLGI408	66	68	40	42	4	7	9	SPHC	EL(무전해 니켈)
	YKBK-S AT66*68	YKBK-SATQ6668	66	68	40	35	4.5	Ø8.5*5.5 Slot	9		ZN(아연)
LG형	YKBK-S 75*75-6T	YKBK-S7575	75	75	40	40	6	9	9*5	SPHC	EL(무전해 니켈)



### YKBK-S (L형) SERIES

STEEL BRACKET-외부보강용

Material SPHC  
 Surface Processing NI(니켈), ZN(아연)  
 Application 강한 체결력을 요하는 작업에 사용

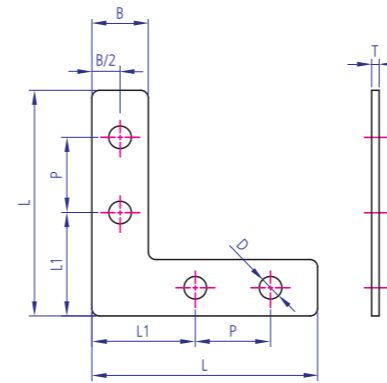

구분	Code	L	L1	P	B	D	T	Material	Plating
표준형	YKBK-S G205-L	YKBK-SGL205	60	27.5	20	15	6	SPHC	NI(니켈)
대영형	YKBK-S G306-L	YKBK-SGL306	80	37.5	30	25	7		ZN(아연)
표준 장공형	YKBK-S G408-L	YKBK-SGL408	105	47.5	40	35	9	SPHC	EL(무전해 니켈)
	YKBK-S D306-L	YKBK-SDL306	80	37.5	30	25	7		ZN(아연)
LG형	YKBK-S D408-L	YKBK-SDL408	105	47.5	40	35	9	SPHC	EL(무전해 니켈)



### YKBK-S (T형) SERIES

STEEL BRACKET-외부보강용

Material SPHC  
 Surface Processing NI(니켈), ZN(아연)  
 Application 강한 체결력을 요하는 작업에 사용

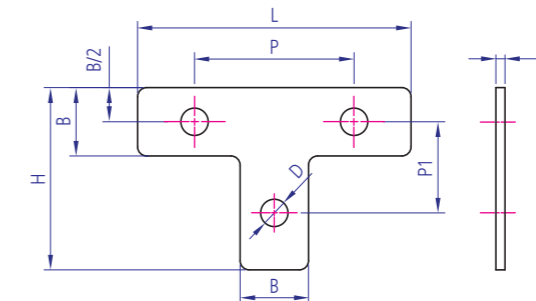

구분	Code	L	P	P1	B	H	D	T	Material	Plating
표준형	YKBK-S G205-T	YKBK-SGT205	60	35	20	15	40	6	SPHC	NI(니켈)
대영형	YKBK-S G306-T	YKBK-SGT306	80	55	30	25	55	7		ZN(아연)
표준 장공형	YKBK-S G408-T	YKBK-SGT408	105	70	45	35	75	9	SPHC	EL(무전해 니켈)
	YKBK-S D306-T	YKBK-SDT306	80	60	55	25	80	7		ZN(아연)
LG형	YKBK-S D408-T	YKBK-SDT408	105	70	40	35	75	9	SPHC	EL(무전해 니켈)



**YKBK-S (+형) SERIES**

STEEL BRACKET-외부보강용

Material SPHC

Surface Processing Ni(니켈), ZN(아연)

Application 강한 체결력을 요하는 작업에 사용

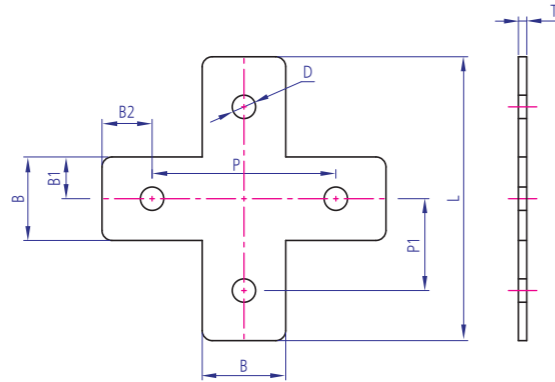
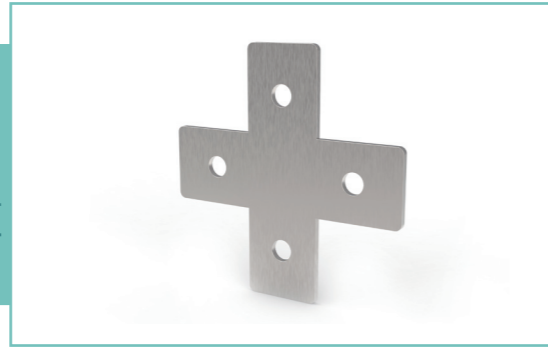

규격	Code	L	P	P1	B	B1	B2	D	T	Material	Plating
YKBK-S G306-+	YKBK-SGC306	85	55	27.5	25	12.5	15	∅7	2.5	SPHC	Ni(니켈) ZN(아연) EL(무전해니켈)
YKBK-S G408-+	YKBK-SGC408	115	70	35	35	17.5	22.5	∅10	3		



Code : YKBK-SS4035  
Code : YKBK-SS4035A

**YKBK-S 태양광용 SERIES**

STEEL BRACKET-직각용

Material SPHC

Surface Processing Ni(니켈), 용융 아연도금

Application 태양광용 구조물 체결에 사용

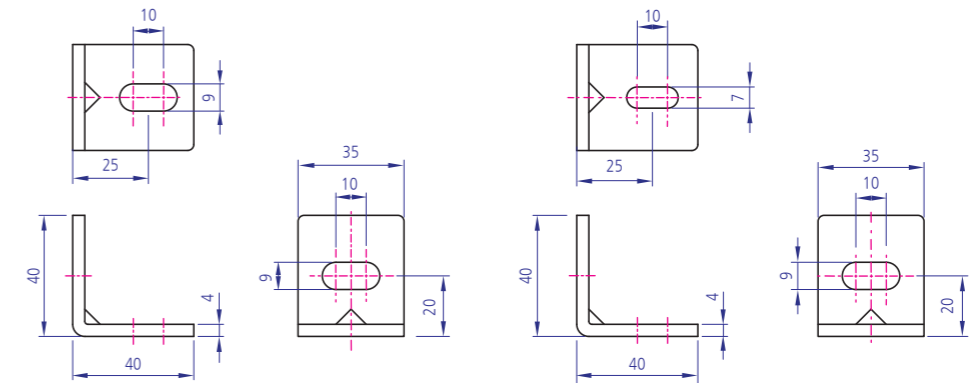

YKBK-S 태양광 40\*35 (SL9\*10)

YKBK-S 태양광 40\*35 (SL9\*10, 7\*10)

**YKBK-S 태양광용 SERIES**

STEEL BRACKET-각도용

Material SPHC

Surface Processing Ni(니켈), 용융 아연도금

Application 태양광용 구조물 체결에 사용

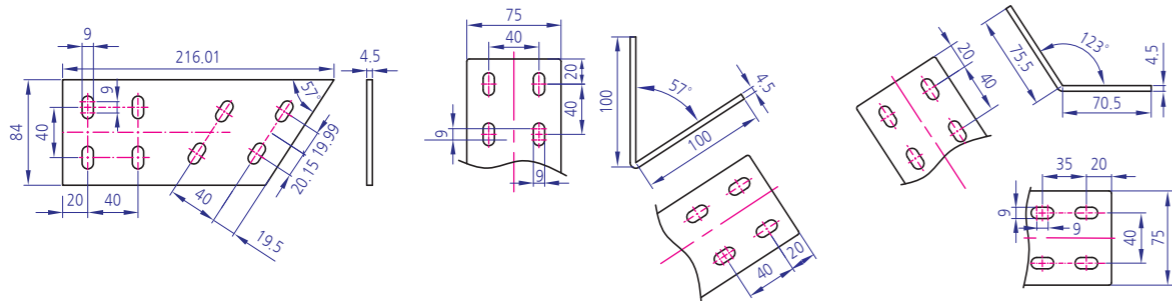

YKBK-S 84\*216\*4.5T  
Code : YKBK-SS84216

YKBK-S 57\*75\*100-4.5T(57°)  
Code : YKBK-SS75100

YKBK-S 123\*75\*75.5-4.5T(123°)  
Code : YKBK-SS7575



Code : YKBK-ID3022  
Code : YKBK-ID4035

**YKIB-D30x22, 40x35(대영용)**

INNER BRACKET

Material ZINC ALLOY

Surface Processing Ni(니켈)

Application 브라켓없이 조립할 수 있는 부품(6mm 홈)

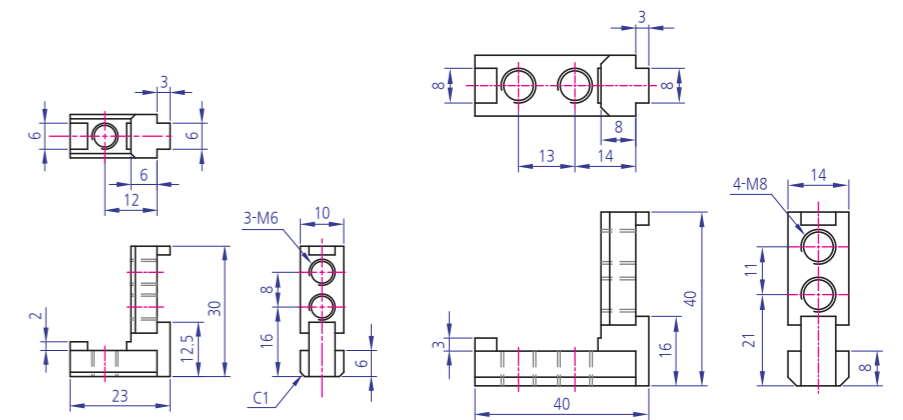
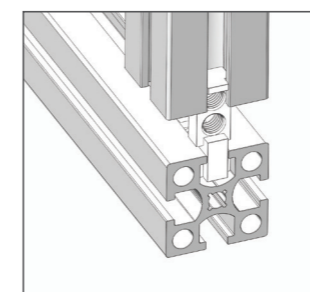

YKIB-D 30x22(대영용)

YKIB-D 40x35(대영용)

**YKIB-G(직각형)**

INNER BRACKET

Material SPHC

Surface Processing NI(니켈)

Application 브라켓없이 조립할 수 있는 부품(6mm 홈)

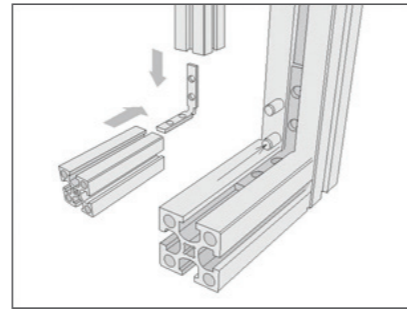
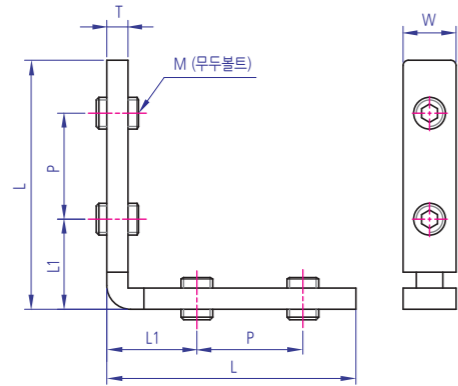

규격	Code	L	L1	T	P	W	M	Material	Plating
YKIB-G205	YKIB-IG205	25	15	2	-	8	5	SPTH	NI
YKIB-G M205	YKIB-IGM205	25	15	3	-	8	5		
YKIB-G306	YKIB-IG306	47	17	4	20	10	6		
YKIB-G408	YKIB-IG408	60	25	5	20	14	8		ZN

**YKIB-G/O(각도형)**

INNER BRACKET

Material SPHC

Surface Processing NI(니켈)

Application 브라켓없이 조립할 수 있는 부품

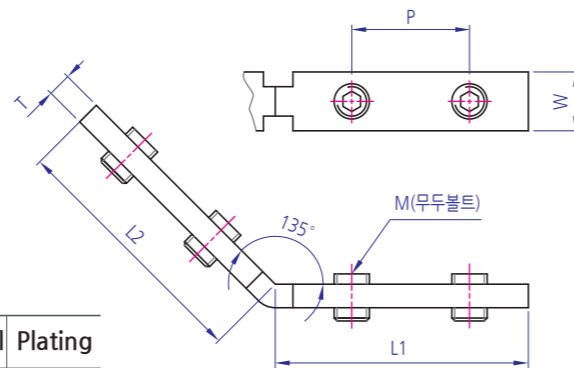

규격	Code	L1	L2	T	P	W	M	Material	Plating
YKIB-O205-135	YKIB-IA205-1	25	25	2	-	8	5	SPTH	NI
YKIB-O M205-135	YKIB-IAM205-1	25	25	3	-	8	5		
YKIB-O306-135	YKIB-IA306-1	43	43	4	20	10	6		
YKIB-O408-135	YKIB-IA408-1	54	54	5	20	14	8		
YKIB-O306-135 (삽입형)	YKIB-IAI306-1	40	46	4	20	10	6		
YKIB-O408-135 (삽입형)	YKIB-IAI408-1	48	60	5	20	14	8		



Code : YKIBK-DG2520  
Code : YKIBK-DG2820

**YKIBK-DC G28x20, G25x20**

AL BRACKET

Material ALDC-12

Surface Processing SILVER(SHOT, 액체도장)

Application 20mm 프로파일용 연결부품

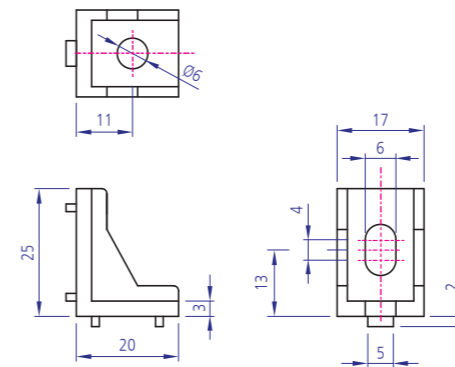

YKIBK-DC G25\*20

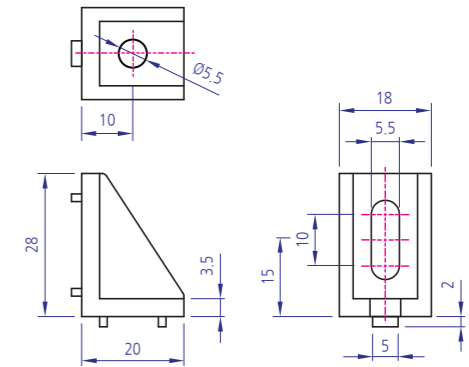

YKIBK-DC G28\*20



**YKIBK-DC G30용**

AL BRACKET

Material ALDC-12

Surface Processing SILVER(SHOT, 액체도장)

Application 30mm 프로파일용 연결부품

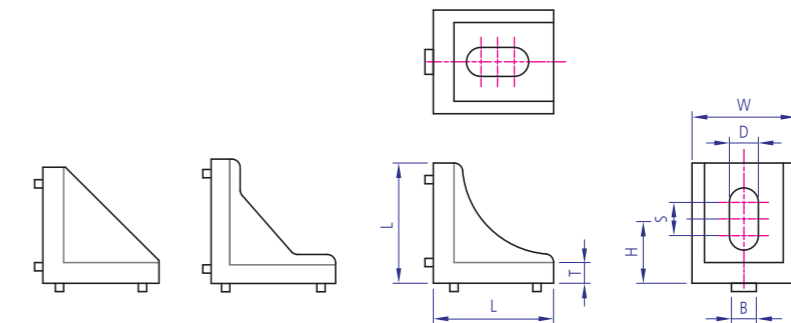

G30\*20

G30\*30

G30\*25

규격	Code	L	W	D	B	H	S	T	Material	Plating
YKIBK-DC G30*20	YKIBK-DG3020	28	20	7	6	14.5	6	5	Short, ALDC12	Painting (Silver)
YKIBK-DC G30*25	YKIBK-DG3025	29	25	7	6	15.5	8	5		
YKIBK-DC G30*30	YKIBK-DG3030	30	25	7	6	16	10	4.5		

**YKBK-DC G30x60**

AL BRACKET

Material ALDC-12

Surface Processing SILVER(SHOT, 액체도장)

Application 30mm 프로파일용 연결부품



Code : YKBK-DG3060

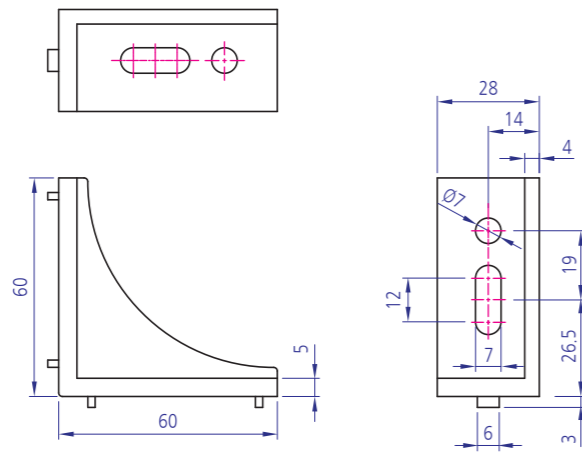

**YKBK-DC G40용**

AL BRACKET

Material ALDC-12

Surface Processing SILVER(SHOT, 액체도장)

Application 40mm 프로파일용 연결부품



규격	Code	L	W	D	B	H	S	T	Material	Plating
YKBK-DC G40*30	YKBK-DG4030	40	30	9	8	23	8	5	ALDC12	Short, Painting (Silver)
YKBK-DC G40*35	YKBK-DG4035	40	35	9	8	21.5	11	6		
YKBK-DC G40*40	YKBK-DG4040	40	35	9	8	22	16	5		

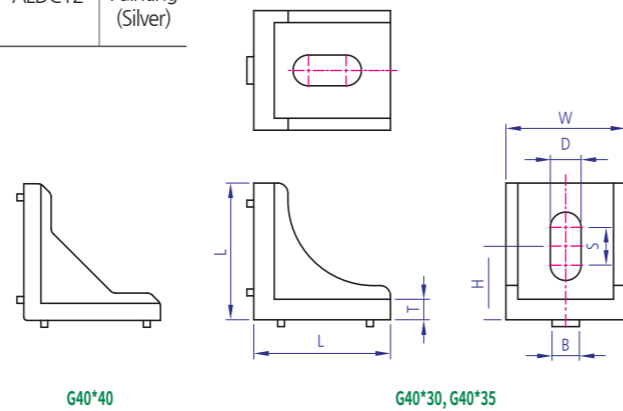

G40\*40

G40\*30, G40\*35

**YKBK-DC G40x80**

AL BRACKET

Material ALDC-12

Surface Processing SILVER(SHOT, 액체도장)

Application 40mm 프로파일용 연결부품



Code : YKBK-DG4080

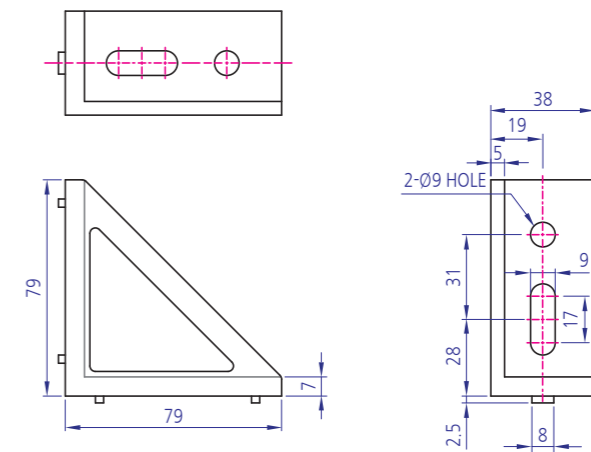

**YKBK-DC G45, G50용**

AL BRACKET

Material ALDC-12

Surface Processing SILVER(SHOT, 액체도장)

Application 45, 50mm 프로파일용 연결부품



규격	Code	L	W	D	B	H	S	T	Material	Plating
YKBK-DC G45*45(M8)	YKBK-DG4545	43	39	8.5	8	24	15	10	ALDC12	Short, Painting (Silver)
YKBK-DC G45*45(M10)	YKBK-DG4545A	43	39	10	10	25	11	10		

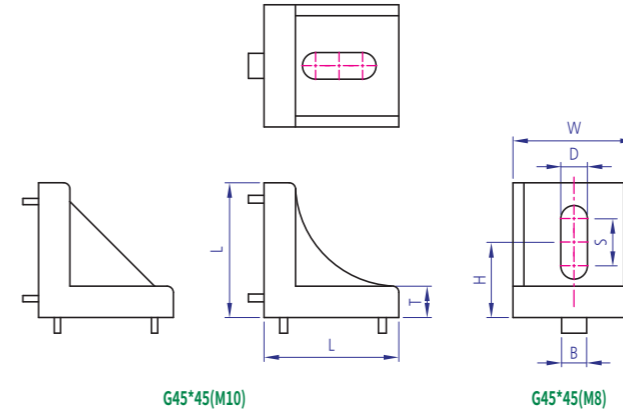

G45\*45(M10)

G45\*45(M8)



**YKBK-DC G45x90**  
AL BRACKET

Material ALDC-12  
Surface Processing SILVER(SHOT, 액체도장)  
Application 45, 50mm 프로파일용 연결부품



Code : YKBK-DG4590

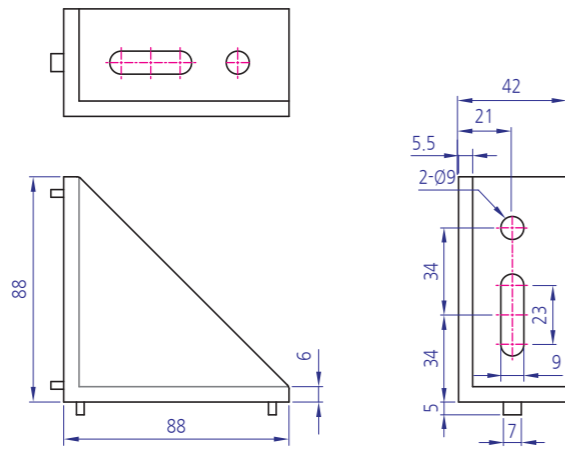

**YKBK-DC G30x55**  
AL BRACKET

Material ALDC-12  
Surface Processing SILVER(SHOT, 액체도장)  
Application 60mm 프로파일용 연결부품



Code : YKBK-DG3055

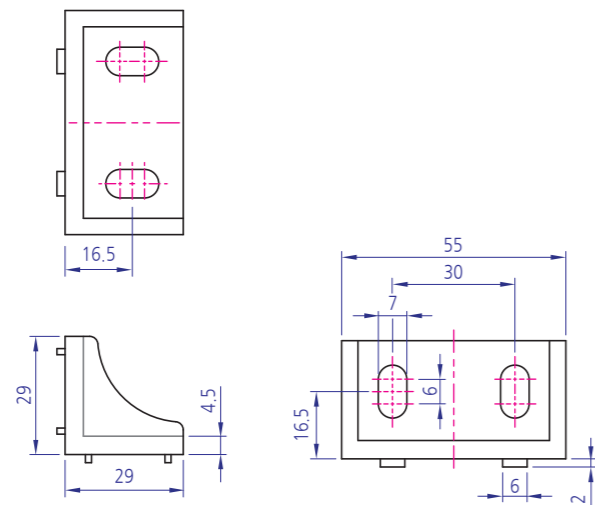

Code : YKBK-DG6055

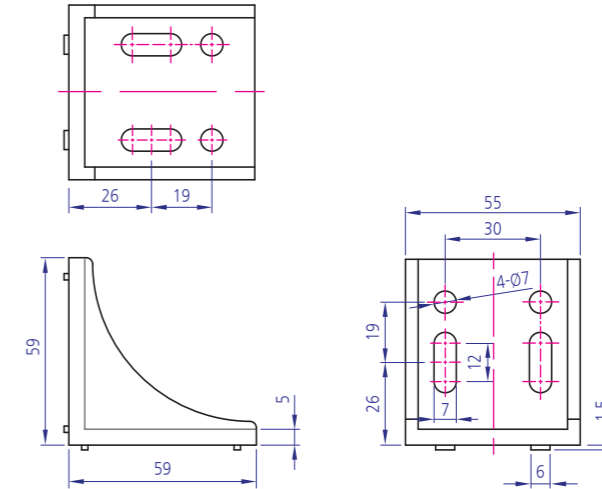

Code : YKBK-DG6060

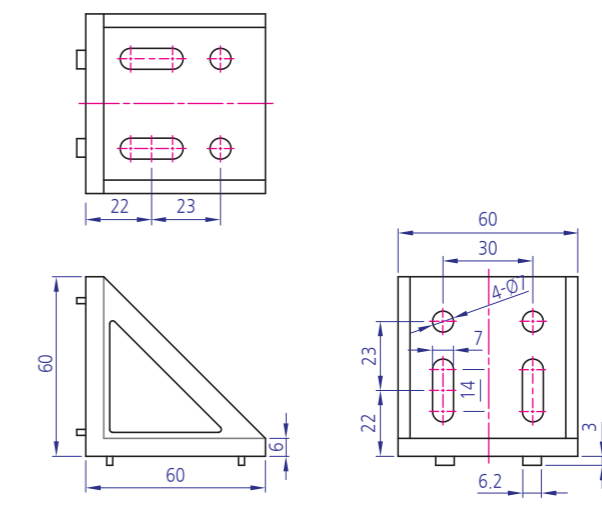

**YKBK-DC G60x55**  
AL BRACKET

Material ALDC-12  
Surface Processing SILVER(SHOT, 액체도장)  
Application 60mm 프로파일용 연결부품

**YKBK-DC G60x60**  
AL BRACKET

Material ALDC-12  
Surface Processing SILVER(SHOT, 액체도장)  
Application 60mm 프로파일용 연결부품

Roller  
Bearing Holder  
Motor Base

Bracket

Multi Block

Joint

Hinge

Magnet

Handle

Foot Base

방진구

Levelling Foot

Cover

End Cap

Bolt

Nut

Washer

Special

Profile

Caster

Roller  
Bearing Holder  
Motor Base

Bracket

Multi Block

Joint

Hinge

Magnet

Handle

Foot Base

방진구

Levelling Foot

Cover

End Cap

Bolt

Nut

Washer

Special

Profile

Caster

**YKBK-DC G40x70, G40x75**  
AL BRACKET

Material ALDC-12  
Surface Processing SILVER(SHOT, 액체도장)  
Application 80mm 프로파일용 연결부품

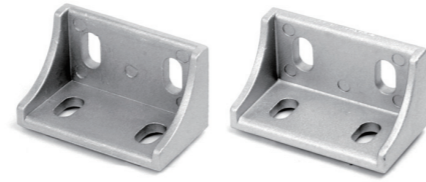

Code : YKBK-DG4070  
Code : YKBK-DG4075

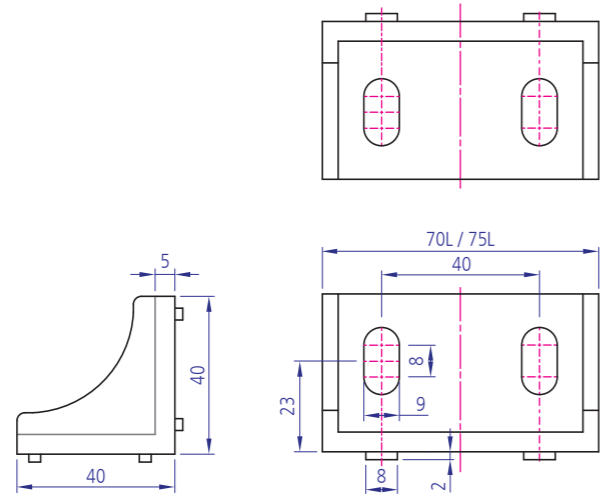

**YKBK-DC G80용 G75x75, G80x75, G80x80**  
AL BRACKET

Material ALDC-12  
Surface Processing SILVER(SHOT, 액체도장)  
Application 80mm 프로파일용 연결부품

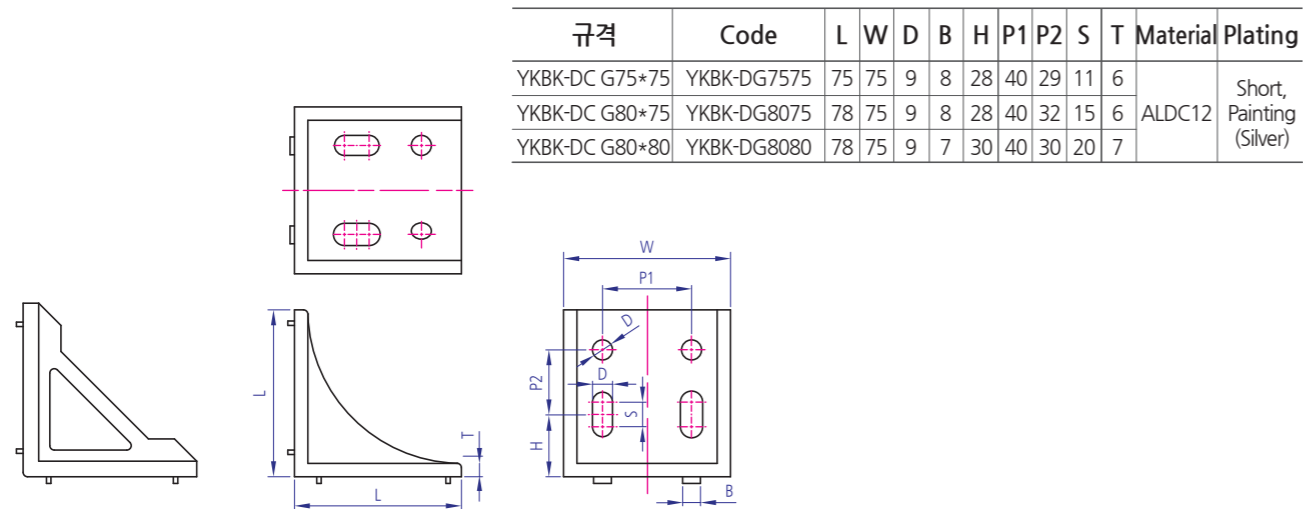

G80\*80

G75\*75, G80\*75



Code : YKBK-DG9090

**YKBK-DC G90x90**  
AL BRACKET

Material ALDC-12  
Surface Processing SILVER(SHOT, 액체도장)  
Application 90mm 프로파일용 연결부품

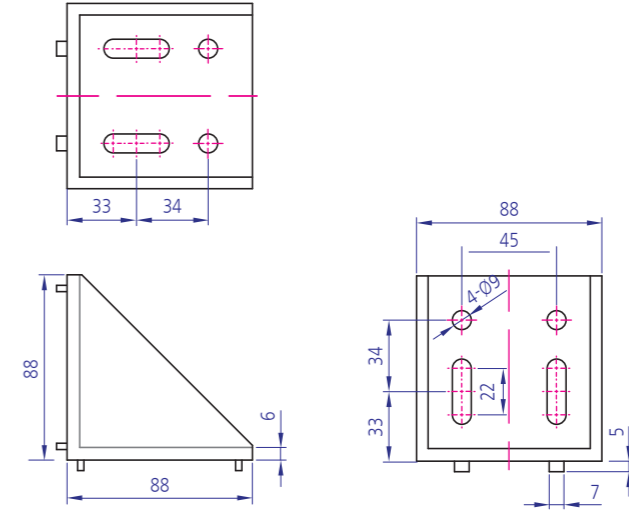

Code : YKBK-AGS7532

**YKBK-AL GS75x32-12T**  
AL BRACKET

Material A6061  
Surface Processing ANODIZING  
Application 40mm 프로파일용 연결부품  
참고 주문생산가능

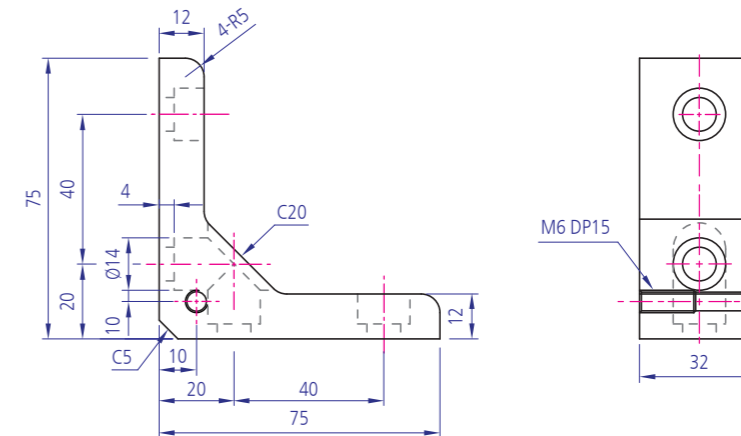

**YKBK-AL GS75x72-12T**  
AL BRACKET

Material A6061  
Surface Processing ANODIZING  
Application 80mm 프로파일용 연결부품  
참고 주문생산가능



Code : YKBK-AGS7572

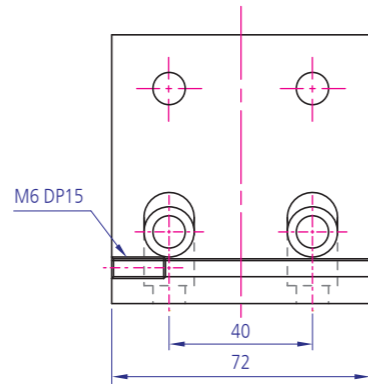
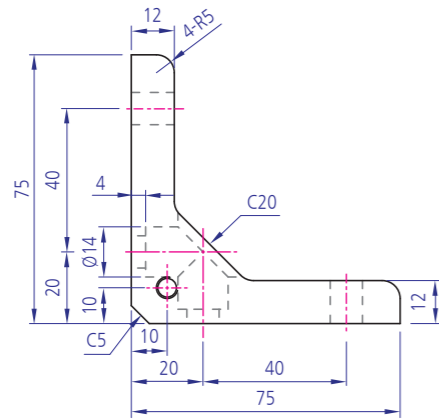

Code : YKBK-AGS75110

**YKBK-AL GS75x110**  
AL BRACKET

Material A6061  
Surface Processing ANODIZING  
Application 120mm 프로파일용 연결부품  
참고 주문생산가능

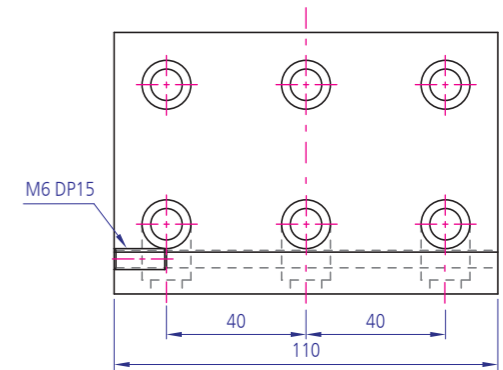
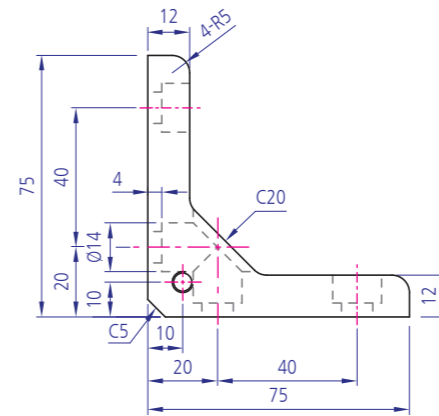

**YKBK-AL GS75x88x12T**  
AL BRACKET

Material A6061  
Surface Processing ANODIZING  
Application 80mm 프로파일용 연결부품



Code : YKBK-AGS7588

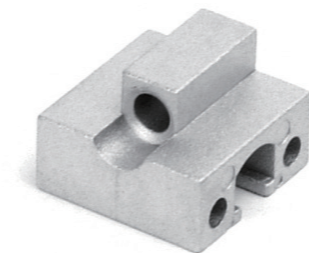
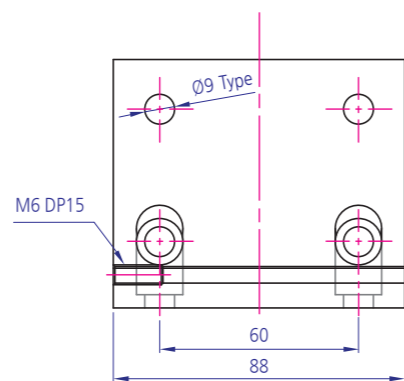
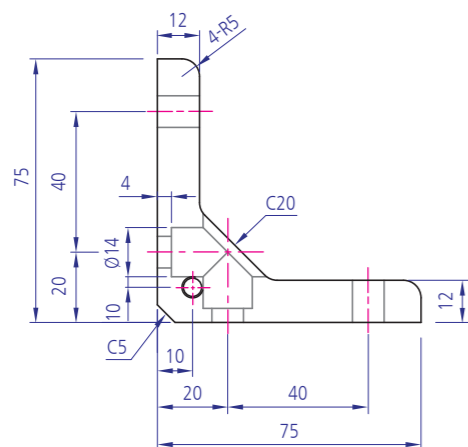

Code : YKBK-DSF30-1S

**YKBK-DC SF30x30x21**  
AL BRACKET

Material ALDC-12  
Surface Processing SILVER(SHOT, 액체도장)  
Application 연결부품

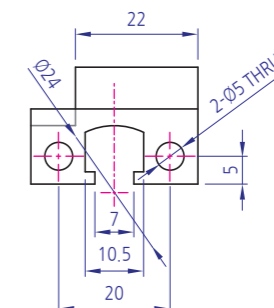
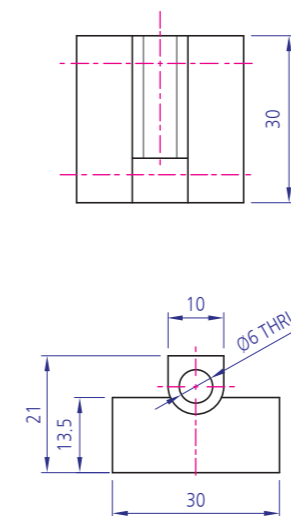

Roller  
Bearing Holder  
Motor Base  
Bracket  
Multi Block  
Joint  
Hinge  
Magnet  
Handle  
Foot Base  
방진구  
Levelling Foot  
Cover  
End Cap  
Bolt  
Nut  
Washer  
Special  
Profile  
Caster

Roller  
Bearing Holder  
Motor Base  
Bracket  
Multi Block  
Joint  
Hinge  
Magnet  
Handle  
Foot Base  
방진구  
Levelling Foot  
Cover  
End Cap  
Bolt  
Nut  
Washer  
Special  
Profile  
Caster



YKBK-DC SF35x30

AL BRACKET

Material ALDC-12

Surface Processing SILVER(SHOT, 액체도장)

Application 프로파일용 연결부품



Code : YKBK-DSF3530S

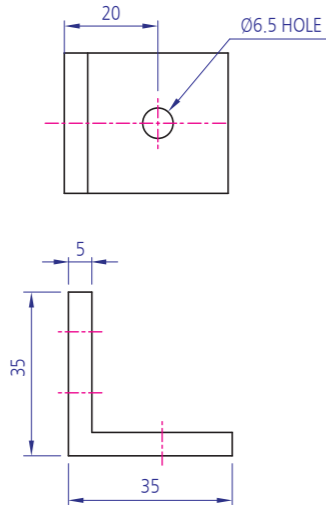

YKBK-DC SF35x60x10T

AL BRACKET

Material ALDC-12

Surface Processing SILVER(SHOT, 액체도장)

Application 프로파일용 연결부품



Code : YKBK-DSF3560S

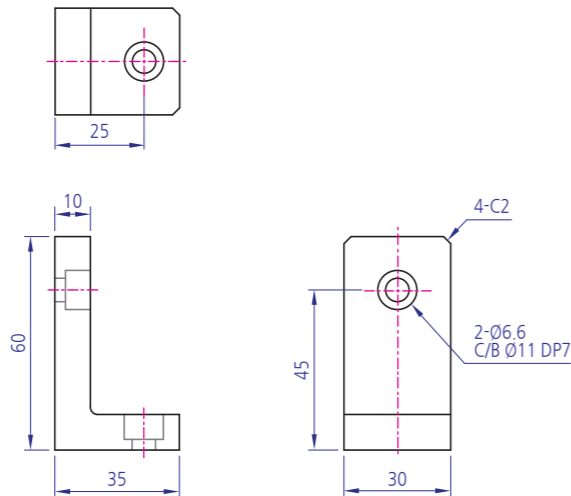

Code : YKBK-DSF4023S

YKBK-DC SF40x23

AL BRACKET

Material ALDC-12

Surface Processing SILVER(SHOT, 액체도장)

Application 프로파일용 연결부품

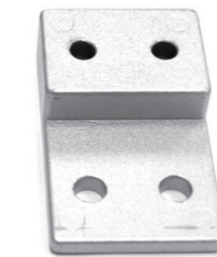
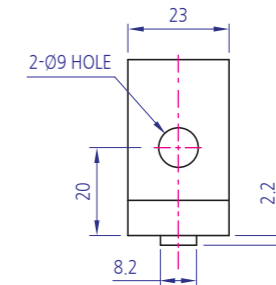
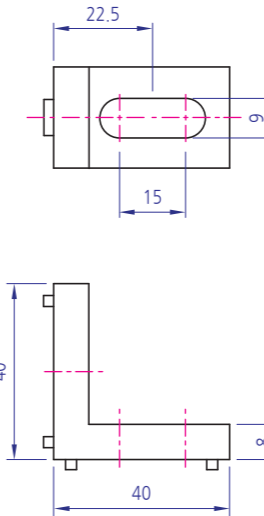

Code : YKBK-DSF4065S

YKBK-DC SF40x65-15T

AL BRACKET

Material ALDC-12

Surface Processing SILVER(SHOT, 액체도장)

Application 30, 40mm 프로파일용 연결부품

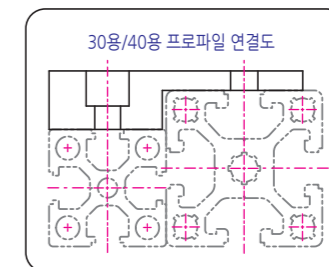
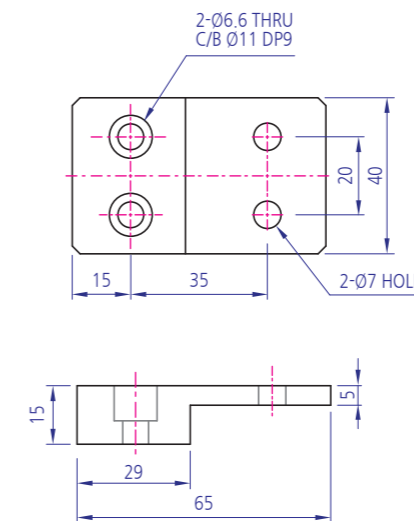

Roller, Bearing Holder, Motor Base, Bracket, Multi Block, Joint, Hinge, Magnet, Handle, Foot Base, 방진구, Levelling Foot, Cover, End Cap, Bolt, Nut, Washer, Special, Profile, Caster

Roller, Bearing Holder, Motor Base, Bracket, Multi Block, Joint, Hinge, Magnet, Handle, Foot Base, 방진구, Levelling Foot, Cover, End Cap, Bolt, Nut, Washer, Special, Profile, Caster

### YKBK-DC SF40x650

AL BRACKET (Support BKT)

Material ALDC-12

Surface Processing 액체도장(SILVER)

Application PDP BUFFER SUPPORT BRACKET



Code : YKBK-DSF40650S

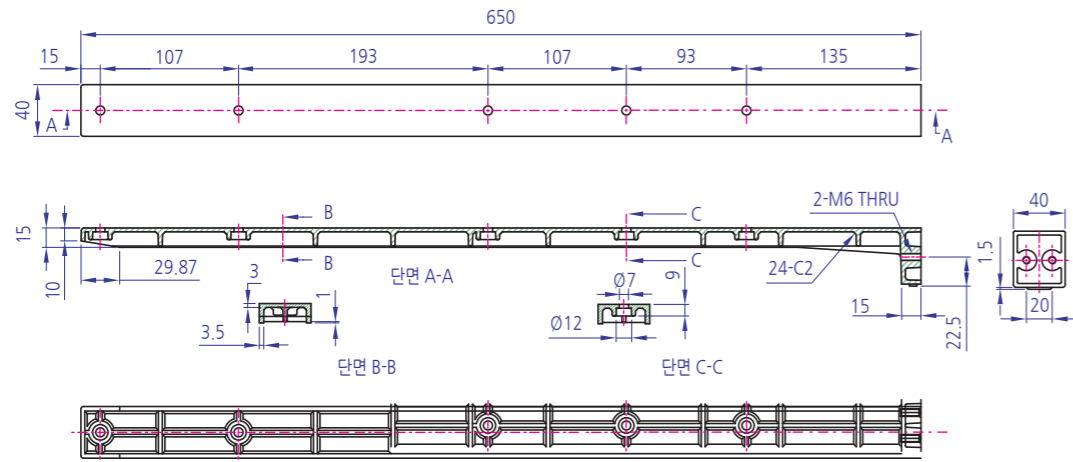

### YKBK-DC SF52x38x28T

AL BRACKET (Sensor Block)

Material ALDC-12

Surface Processing 액체도장(SILVER)

Application SENSOR 고정용



Code : YKBK-DSF5238S

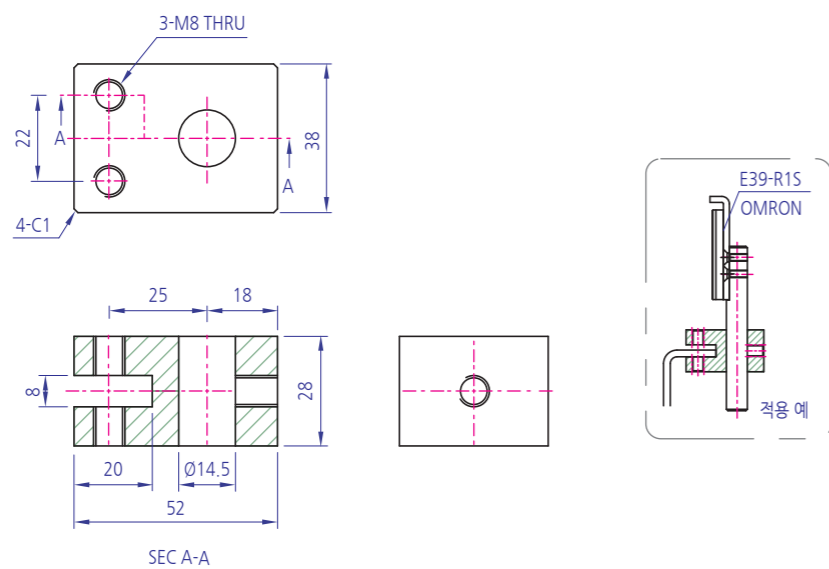

SEC A-A



Code : YKBK-DSF5528S

### YKBK-DC SF55x55x28

AL BRACKET

Material ALDC-12

Surface Processing SILVER(SHOT, 액체도장)

Application 30mm 프로파일용 연결부품

참고 CAP마개 삽입(END CAP part참조)

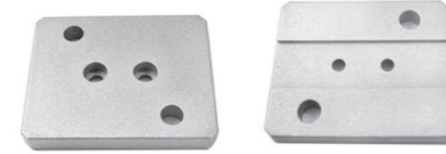
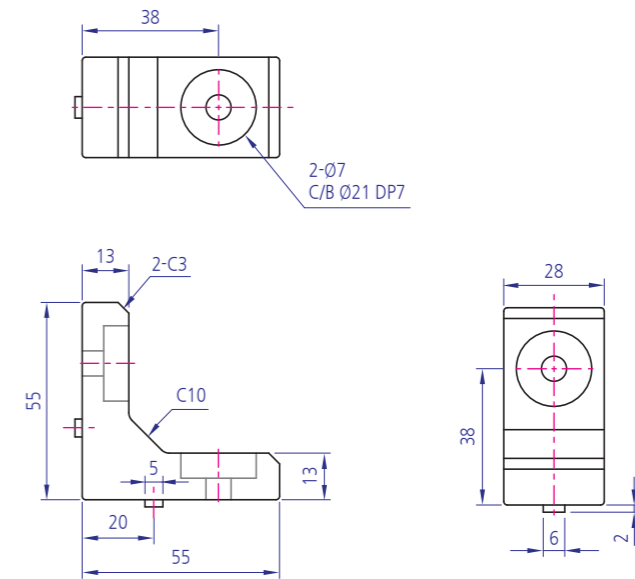

Code : YKBK-DSF6074S

### YKBK-DC SF60x74x9T

AL BRACKET

Material ALDC-12

Surface Processing SILVER(SHOT, 액체도장)

Application 프로파일용 연결부품

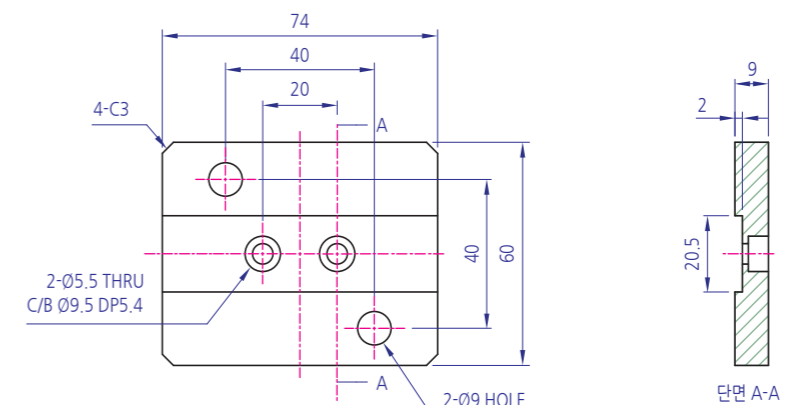

단면 A-A

Roller  
Bearing Holder  
Motor Base  
Bracket  
Multi Block  
Joint  
Hinge  
Magnet  
Handle  
Foot Base  
방진구  
Leveling Foot  
Cover  
End Cap  
Bolt  
Nut  
Washer  
Special  
Profile  
Caster

Roller  
Bearing Holder  
Motor Base  
Bracket  
Multi Block  
Joint  
Hinge  
Magnet  
Handle  
Foot Base  
방진구  
Leveling Foot  
Cover  
End Cap  
Bolt  
Nut  
Washer  
Special  
Profile  
Caster

### YKBK-DC SF60x80-D28

AL BRACKET (파이프 서포트)

Material ALDC-12

Surface Processing SILVER(SHOT, 액체도장)

Application 파이프 고정용 브라켓



Code : YKBK-DSF608028S

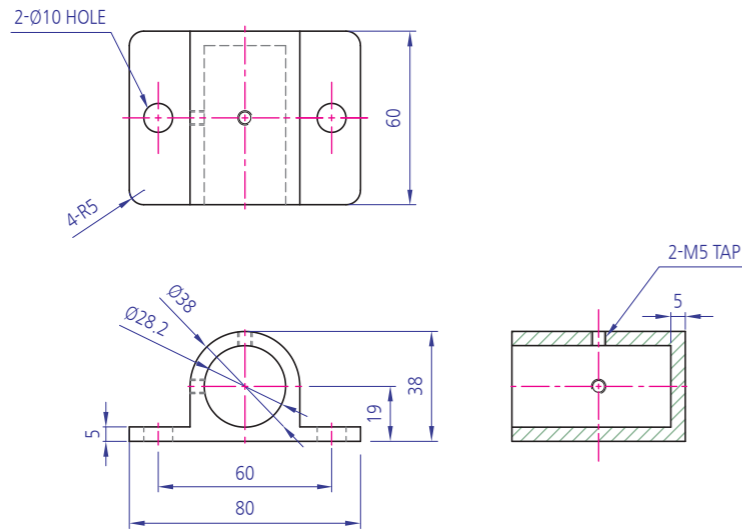

### YKBK-DC SF65x34x10T

AL BRACKET

Material ALDC-12

Surface Processing SILVER(SHOT, 액체도장)

Application 프로파일용 연결부품



Code : YKBK-DSF6534S

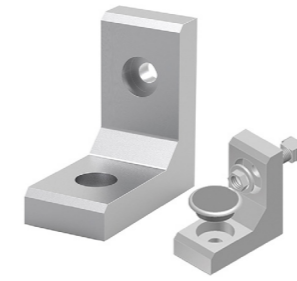
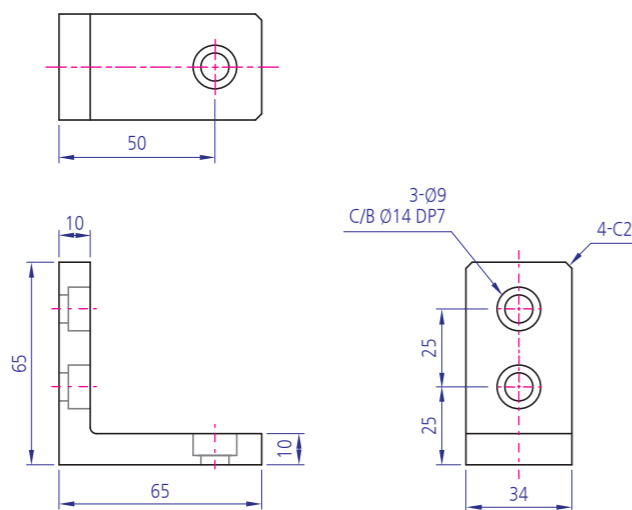

Code : YKBK-DSF7538S

### YKBK-DC SF75x75x38

AL BRACKET

Material ALDC-12

Surface Processing SILVER(SHOT, 액체도장)

Application 40mm 프로파일용 연결부품

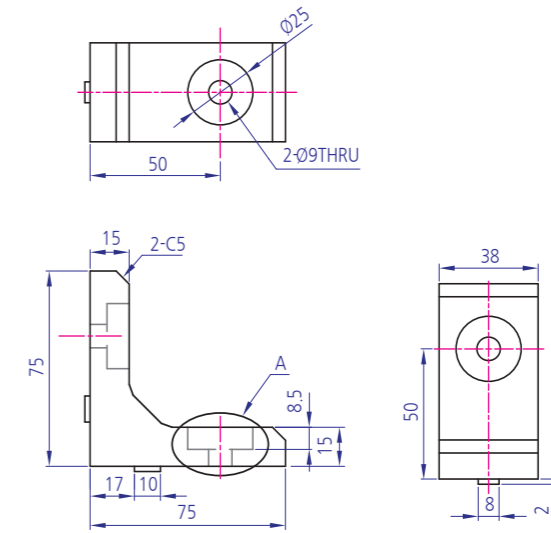

Code : YKBK-DSF7578S

### YKBK-DC SF75x75x78

AL BRACKET

Material ALDC-12

Surface Processing SILVER(SHOT, 액체도장)

Application 80mm 프로파일용 연결부품, 중량형

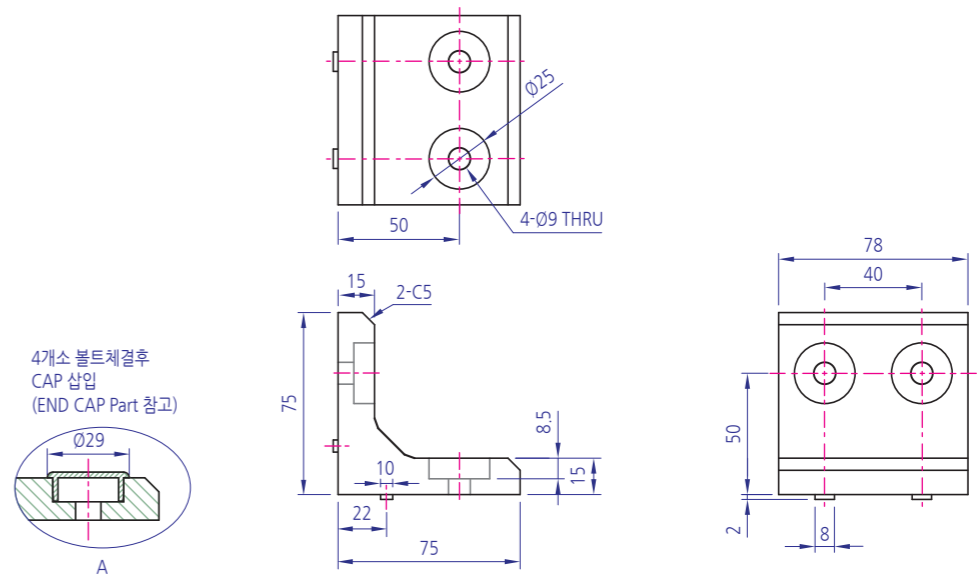



**YKBK-DC SF80x80-D28**

AL BRACKET (Sensor Block)

Material ALDC-12

Surface Processing SILVER(SHOT, 액체도장)

Application 파이프 고정용 브라켓



Code : YKBK-DSF808028S

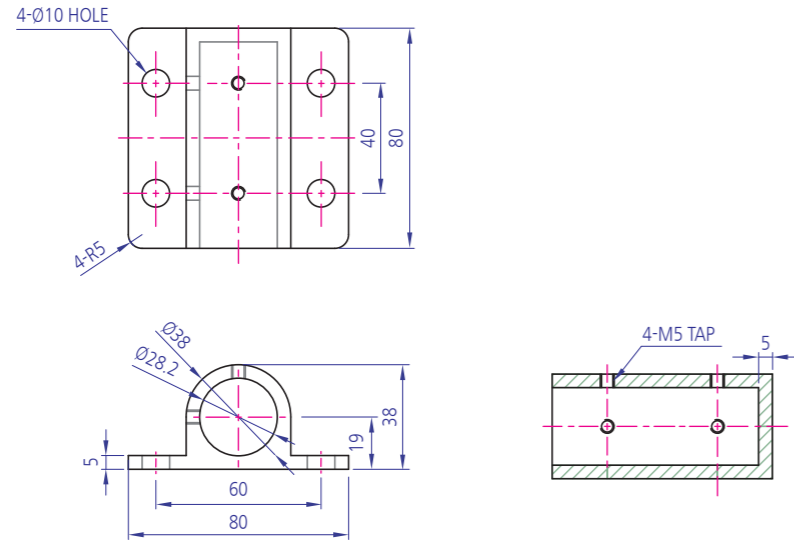

**YKBK-DC SF80x80x28**

AL BRACKET

Material ALDC-12

Surface Processing SILVER(SHOT, 액체도장)

Application 30mm 프로파일용 연결부품

참고 CAP마개 삽입(END CAP part참조)



Code : YKBK-DSF8028S

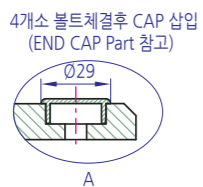
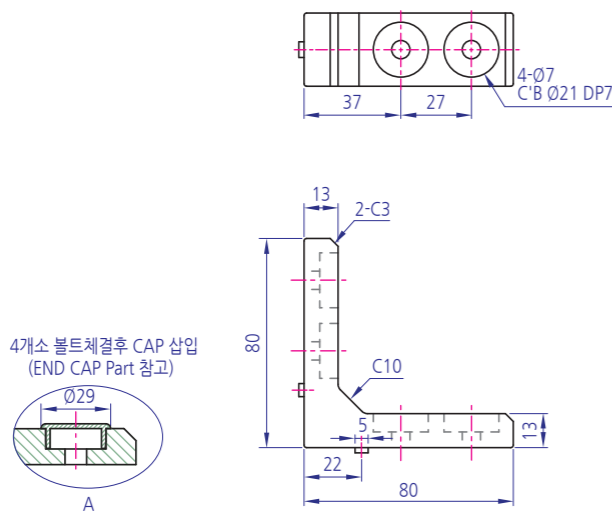

Code : YKBK-DSF10078S

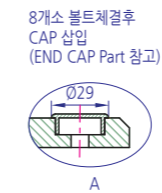
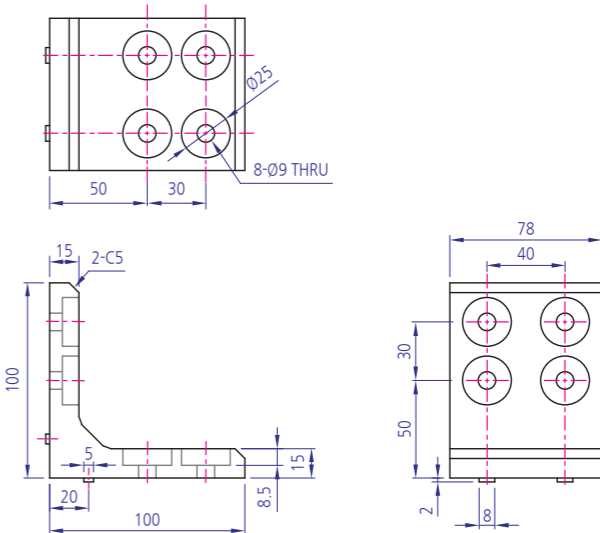

**YKBK-DC SF100x100x78**

AL BRACKET

Material ALDC-12

Surface Processing SILVER(SHOT, 액체도장)

Application 80mm 프로파일용 연결부품

**YKBK-DC SF100x100x38**

AL BRACKET

Material ALDC-12

Surface Processing SILVER(SHOT, 액체도장)

Application 40mm 프로파일용 연결부품



Code : YKBK-DSF10038S

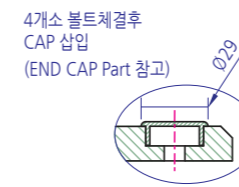
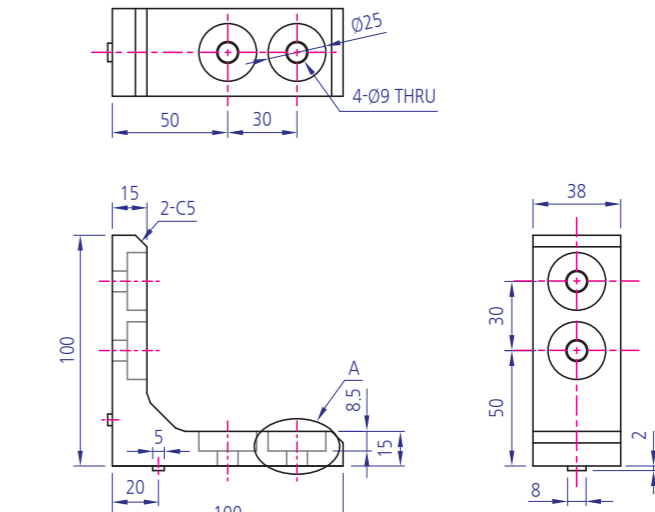

**YKBK-DC OS SERIES**

AL BRACKET-외부보강용

Material ALDC-12

Surface Processing SILVER(액체도장)

Application FRAME 조립후 외부보강용으로 사용됨

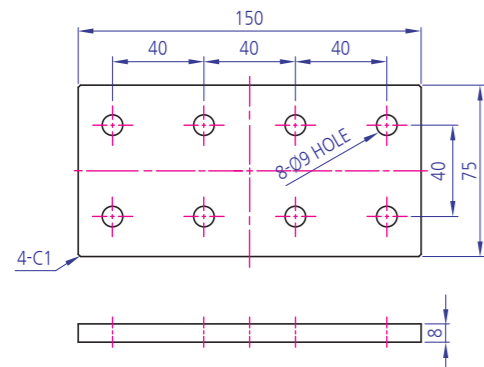
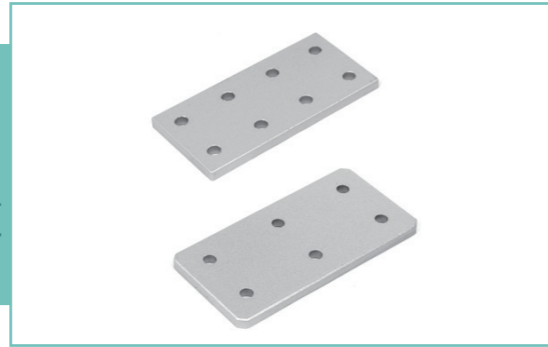

**YKBK-DC OS 75x150**  
Code : YKBK-DOS75150  
Code : YKBK-DOS75150B(흑착)

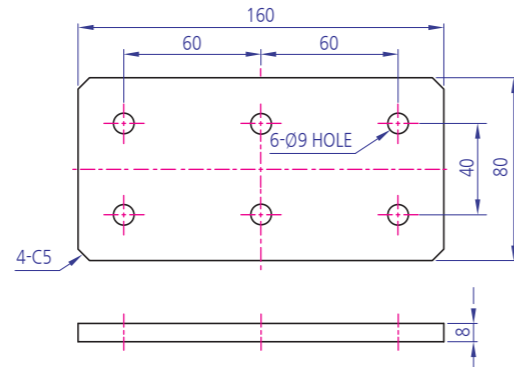

**YKBK-DC OS 80x160**  
Code : YKBK-DOS80160

**YKBK-DC OS200x140x12T**

AL BRACKET-외부보강용, SIDE JOINT PL ATE

Material ALDC-12

Surface Processing SHOT

Application FRAME 조립후 외부보강용으로 사용됨, RAIL 연결부품



Code : YKBK-DOS200140

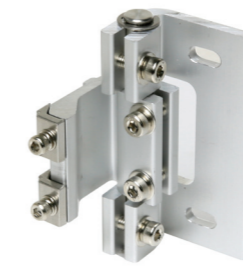
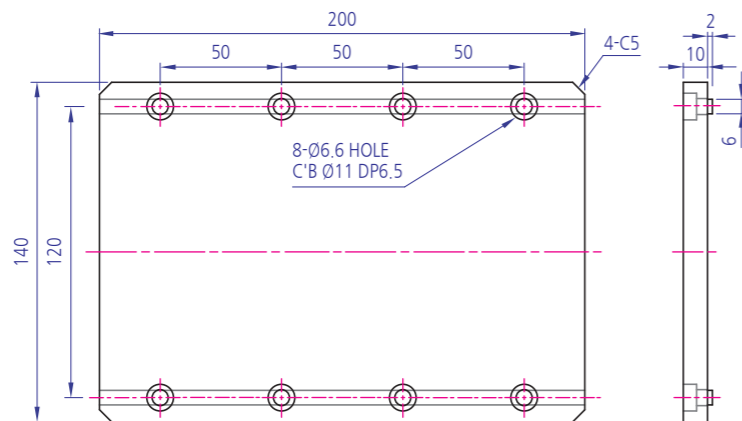

Code : YKBK-A68-1

**YKBK-센서브라켓**

AL BRACKET

Material AL6063

Surface Processing Anodizing

Application Sensor Bracket, setting angle -7~110

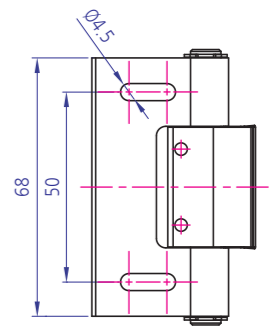
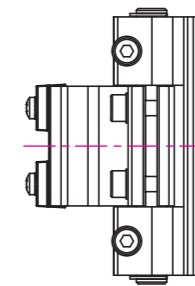
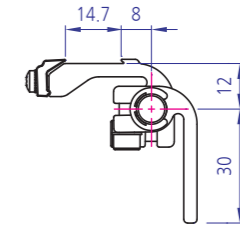
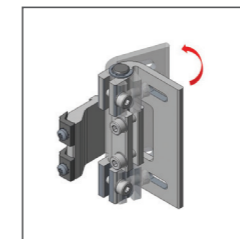
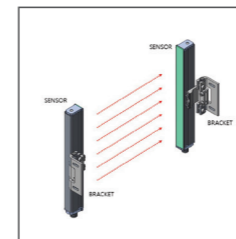

**YKBK-RCBK 30**

AL BRACKET

Material ZINC ALLOY

Surface Processing NI(니켈)

Application 프로파일용 연결부품

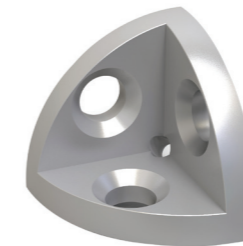

Code : YKBK-DRC30

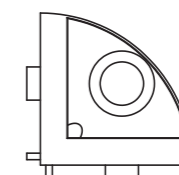
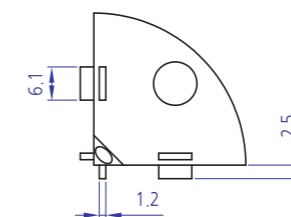
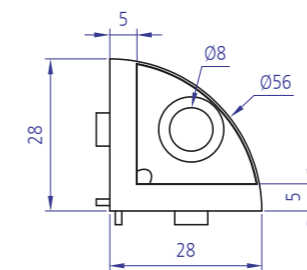

Roller  
 Bearing Holder  
 Motor Base  
**Bracket**  
 Multi Block  
 Joint  
 Hinge  
 Magnet  
 Handle  
 Foot Base  
 방진구  
 Levelling Foot  
 Cover  
 End Cap  
 Bolt  
 Nut  
 Washer  
 Special  
 Profile  
 Caster

Roller  
 Bearing Holder  
 Motor Base  
**Bracket**  
 Multi Block  
 Joint  
 Hinge  
 Magnet  
 Handle  
 Foot Base  
 방진구  
 Levelling Foot  
 Cover  
 End Cap  
 Bolt  
 Nut  
 Washer  
 Special  
 Profile  
 Caster

**YKBK-RCBK 40**

AL BRACKET

Material ZINC ALLOY  
 Surface Processing NI(니켈)  
 Application 프로파일용 연결부품

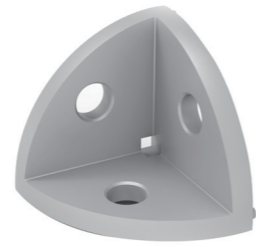

Code : YKBK-DRC40

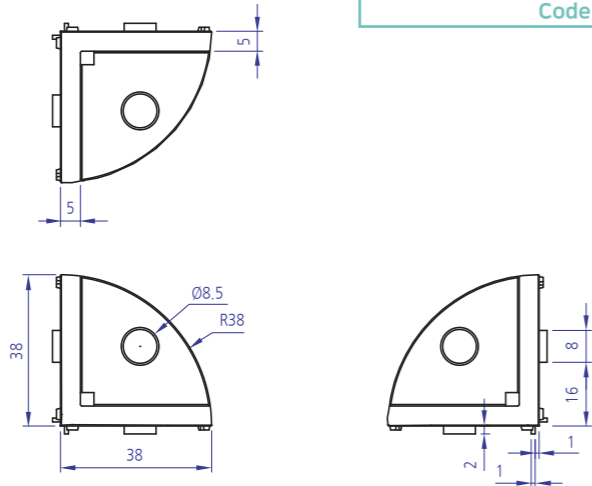

**YKAJ M6 / M8**

FREE ANGLE BRACKET(각도조절 브라켓)

Material ZINC ALLOY  
 Surface Processing SILVER(액체도장)  
 Application 각도조절이 필요한 작업시, 혹은 일반 HINGE의 하중을 넘어서는 DOOR용 HINGE 용도로 사용

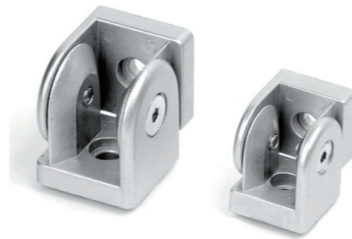

Code : YKBK-EAJM6  
 Code : YKBK-EAJM8

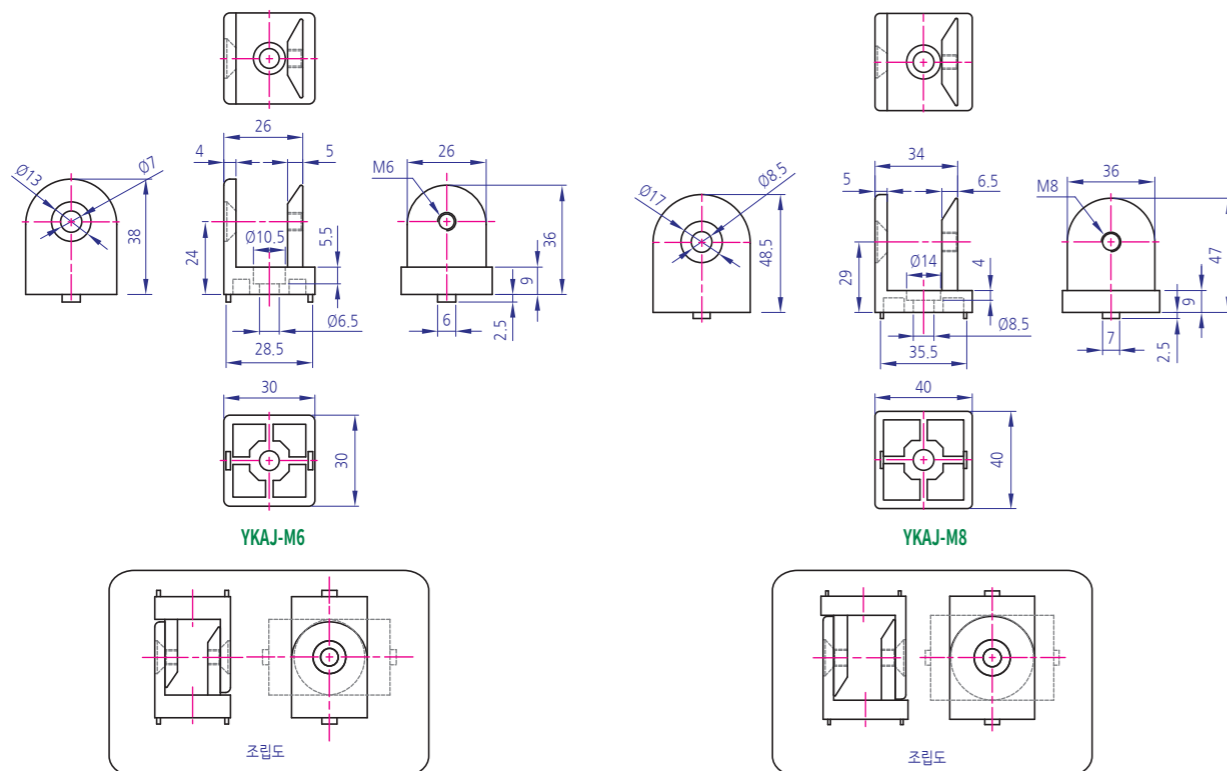

**YKBK-DC LF90x38x13T**  
 AL BRACKET(LADDER PIPE B.K)

Material ALDC-12, AL6061  
 Surface Processing SILVER(SHOT, 액체도장), ANODIZING  
 Application 사다리 고정용 브라켓(Ø34용)

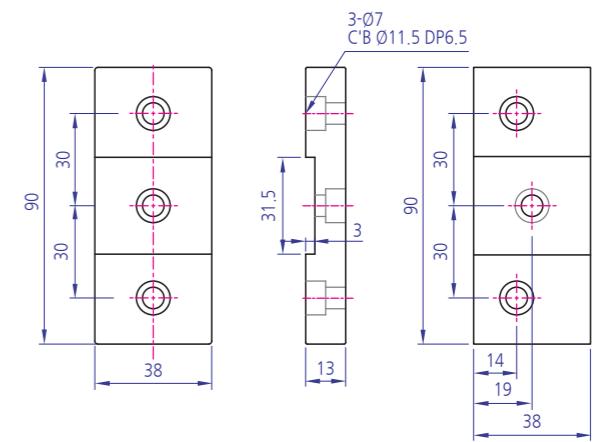
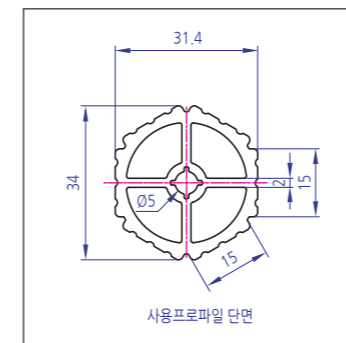

표준형(ALDC-12)  
 Code : YKLD-BK34-9038

편심형(AL6061)  
 Code : YKLD-BK34-9038A



**YKSH M6, M8**

SLIDE HOOK

Material PVC, STEEL  
 Surface Processing BLACK(흑),ZN(아연)  
 Application 행거용(공구, 커튼)부품

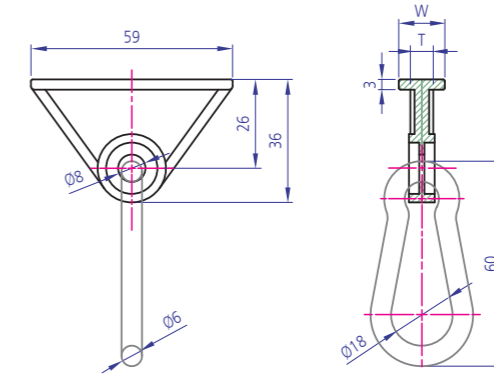

규격	Code	W	T	Material
YKSH-M6	YKBK-ESH6	9.5	6	PVC
YKSH-M8	YKBK-ESH8	13.5	7	STEEL

### YKBK-DC LF70x40x13T AL BRACKET(LADDER PIPE B.K)

Material AL6061  
Surface Processing ANODIZING  
Application 사다리 고정용 브라켓(Ø30용)



Code : YKLD-BK30-4070

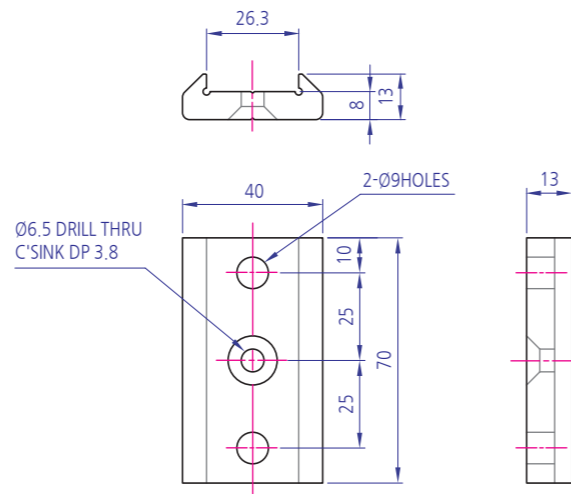
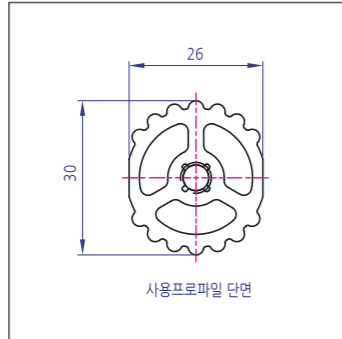

### YKBK-DC 45x21.5x16T AL BRACKET

Material ALDC12  
Surface Processing 액체도장(SILVER)  
Application Chain Roller Shaft 고정용

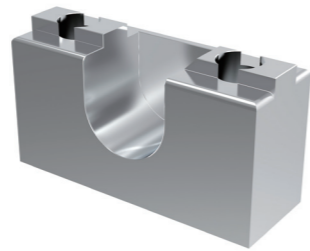

Code : YKBK-DE4521

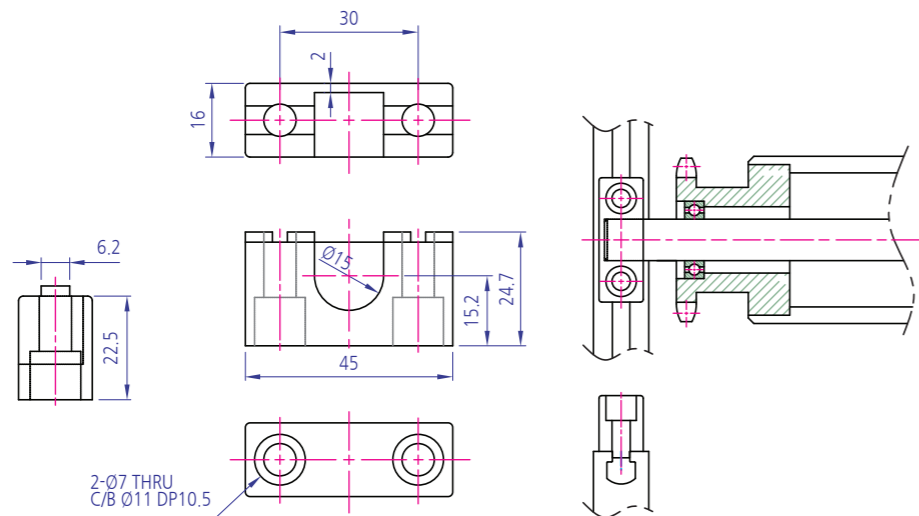

### GEAR BOX BRACKET L,R 54x30x61.7 AL BRACKET

Material ALDC12  
Surface Processing 액체도장(SILVER)  
Application GEAR BOX 고정용

L Code : YKGB-BK5430A  
R Code : YKGB-BK5430B

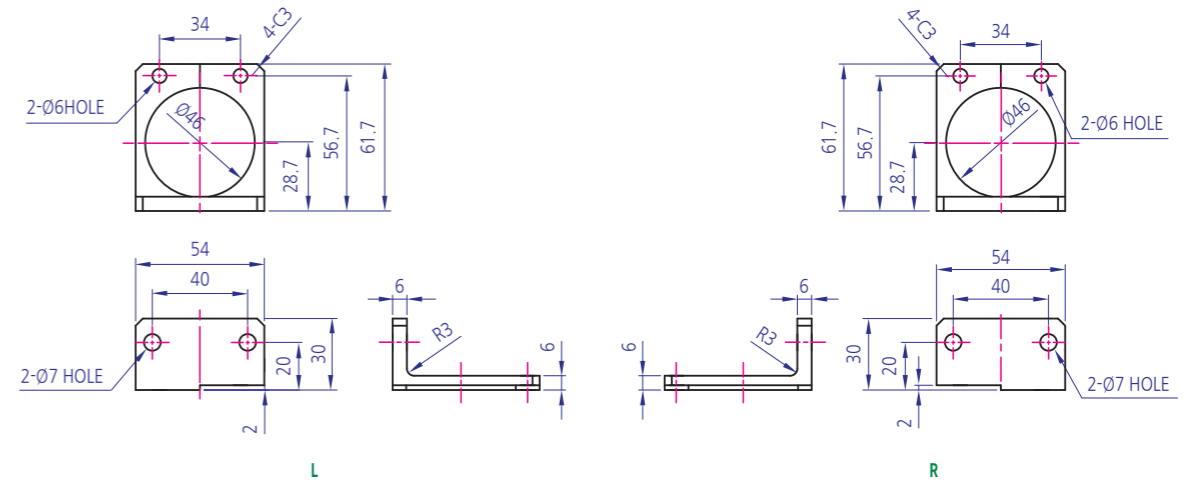

### YKBK-CLAMP BLOCK 375x108x8 AL BRACKET-CLAMP BLOCK

Material ALDC12  
Surface Processing 테프론(흑)  
Application CLAMP BLOCK

Code : YKCL-B3751088-2

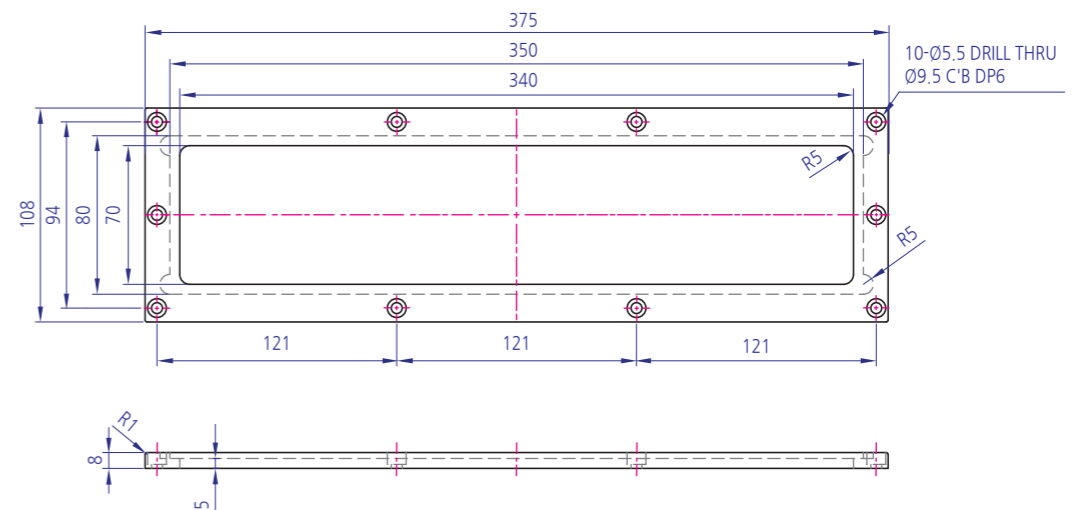



**YKBK-DC 34x20x22.5**  
AL BRACKET

Material ALDC12  
Surface Processing 액체도장(SILVER)  
Application RF Sensor 고정용

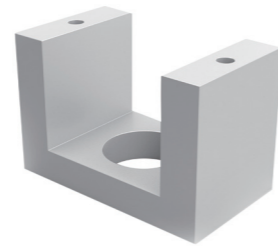

Code : YKBK-DE34-1S

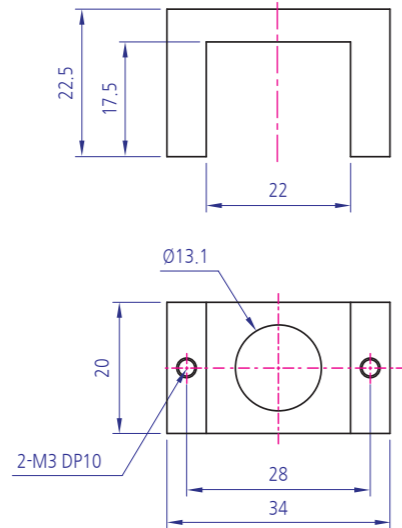

**YKBK-DC 40x72x25**  
AL BRACKET

Material ALDC12  
Surface Processing 액체도장(SILVER)  
Application 컨베이어용 브라켓

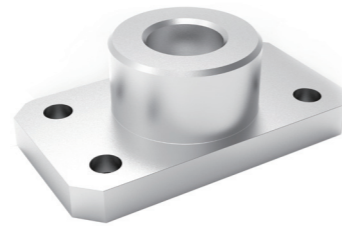

Code : YKBK-DE4072E

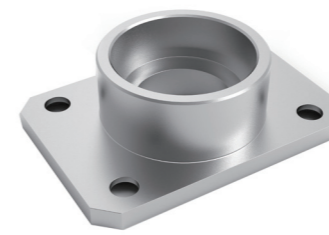
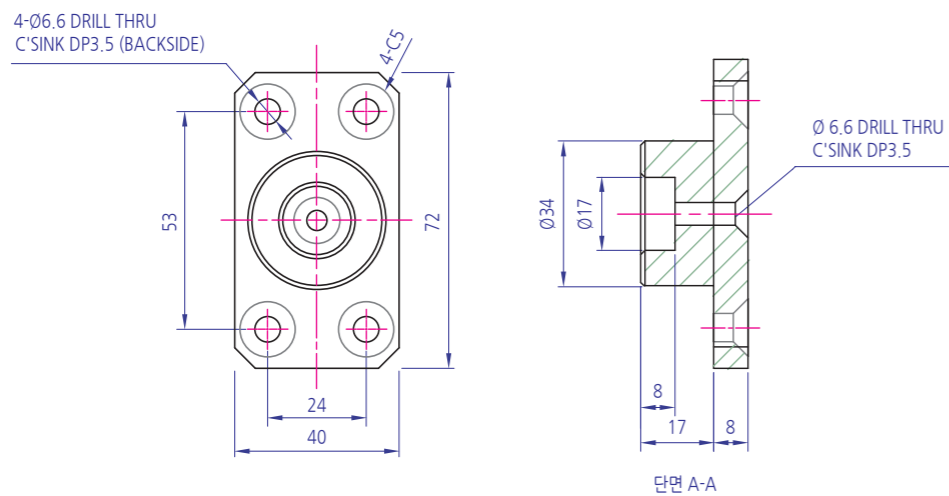

Code : YKBK-DE5072E

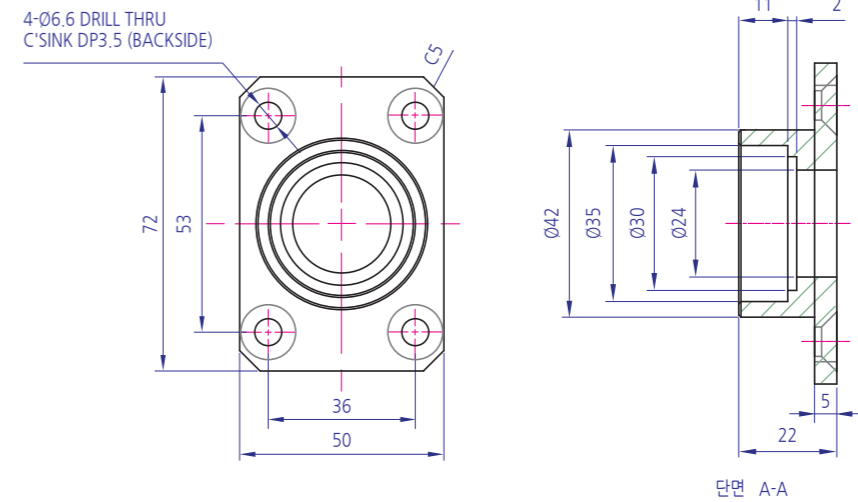

**YKBK-DC 50x72x22**  
AL BRACKET

Material ALDC12  
Surface Processing EL(무전해니켈)  
Application 베어링 브라켓

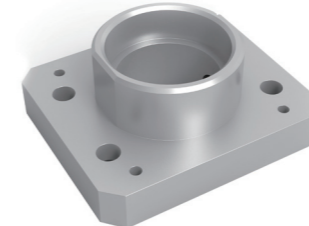

Code : YKBK-DM6070E

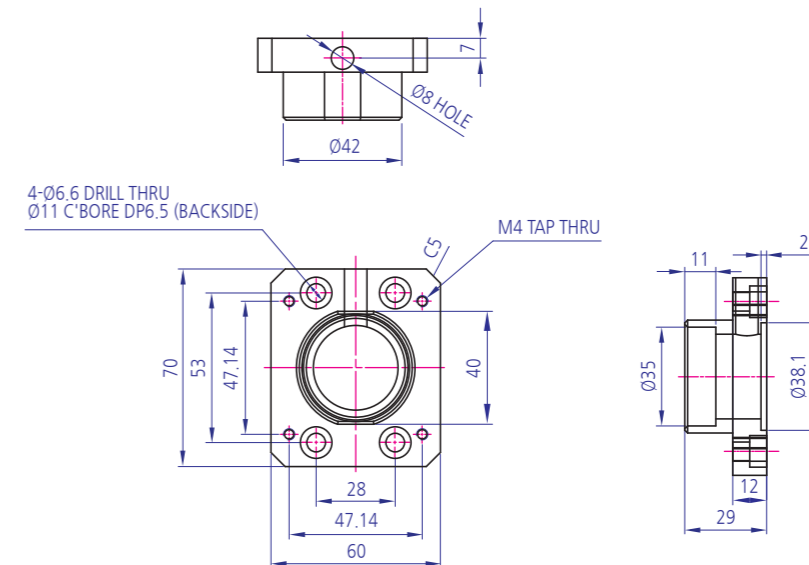

**YKBK-DC 60x70x29**  
AL BRACKET

Material ALDC12  
Surface Processing EL(무전해니켈)  
Application MOTER BRACKET

Roller  
Bearing Holder  
Motor Base

Bracket

Multi Block

Joint

Hinge

Magnet

Handle

Foot Base

방진구

Leveling Foot

Cover

End Cap

Bolt

Nut

Washer

Special

Profile

Caster

Roller  
Bearing Holder  
Motor Base

Bracket

Multi Block

Joint

Hinge

Magnet

Handle

Foot Base

방진구

Leveling Foot

Cover

End Cap

Bolt

Nut

Washer

Special

Profile

Caster

**YKBK-DC 60x40x10**  
AL BRACKET

Material ALDC12  
Surface Processing 액체도장(SILVER)  
Application DOOR 고정용



Code : YKBK-DE60-1S

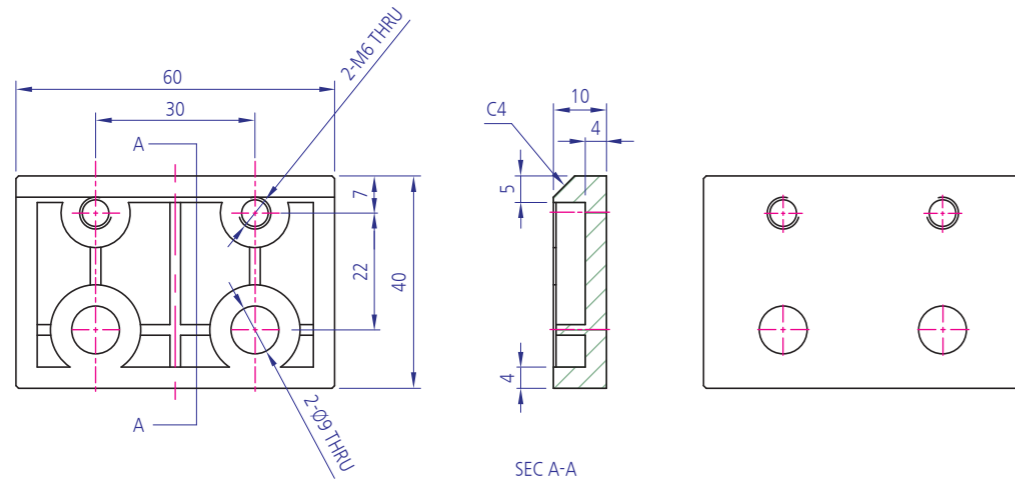

**YKBK-DC 60x25x20**  
AL BRACKET

Material ALDC12  
Surface Processing 액체도장(SILVER)  
Application DOOR 고정용

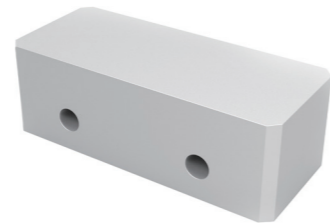

Code : YKBK-DE60-2S

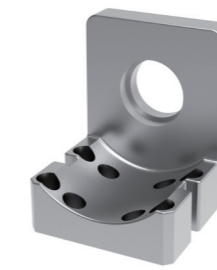
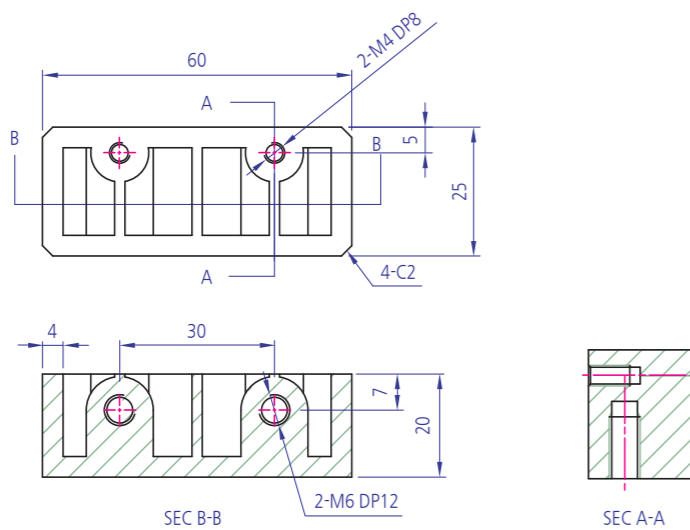

Code : YKBK-DE10080A

**YKBK-DC-100x80x80-1**  
AL CASTING

Material ALDC12  
Surface Processing 액체도장(SILVER)  
Application 모터고정용, SUPPORT BLOCK

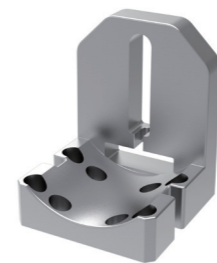
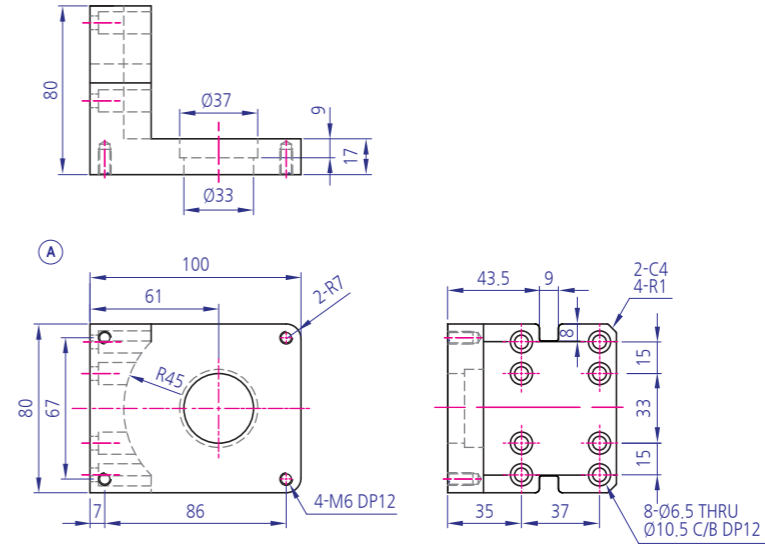

Code : YKBK-DE10080

**YKBK-DC-100x80x80-2**  
AL CASTING

Material ALDC12  
Surface Processing 액체도장(SILVER)  
Application 모터고정용, TENSION BLOCK

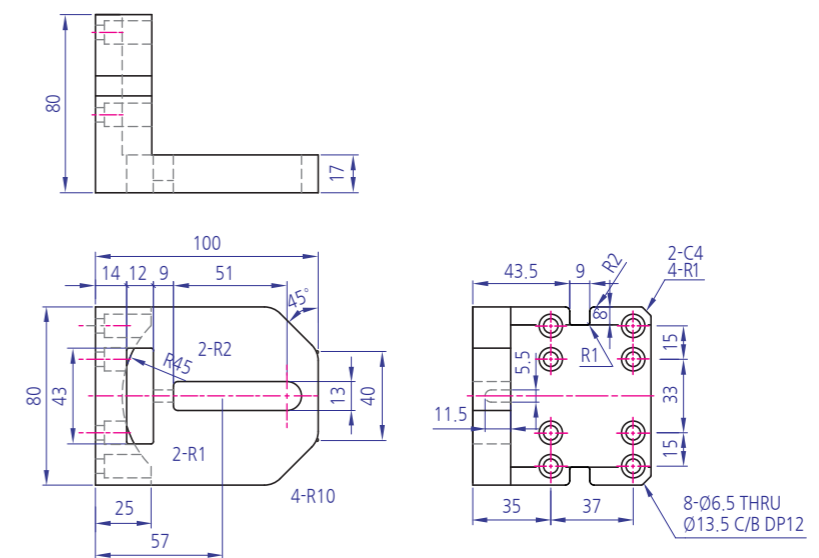

### YKBK-DC 100x36x28

AL BRACKET

Material ALDC12

Surface Processing 액체도장(SILVER)

Application Air 연결용

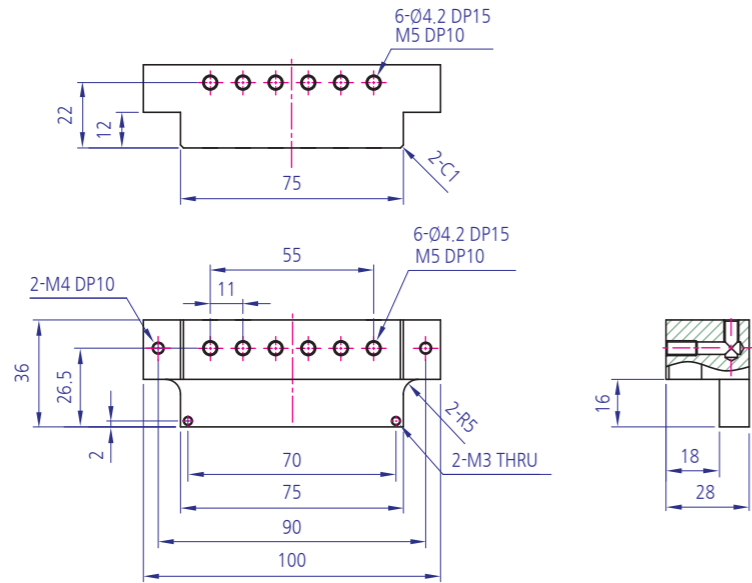

### YKBK-D-137x68x20\_SLS

AL BRACKET

Material ALDC12

Surface Processing Black 무정전 분체도장

Application Guide Roller suport/Buffer BKT

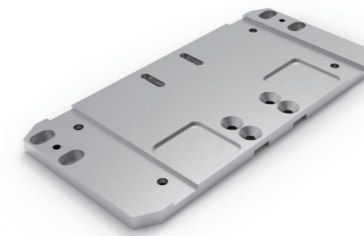
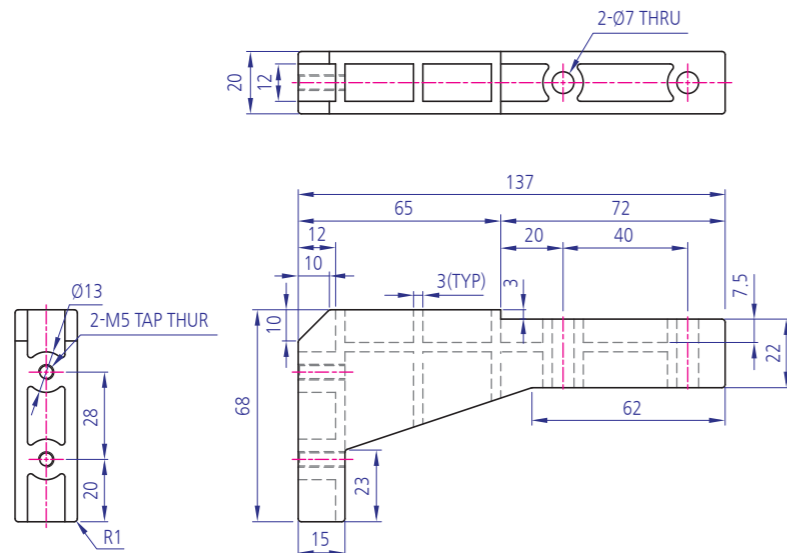

### YKBK-DC 250x120x10

AL BOTTOM BASE PLATE

Material ALDC12

Surface Processing 액체도장(SILVER)

Application BOTTOM BASE PLATE

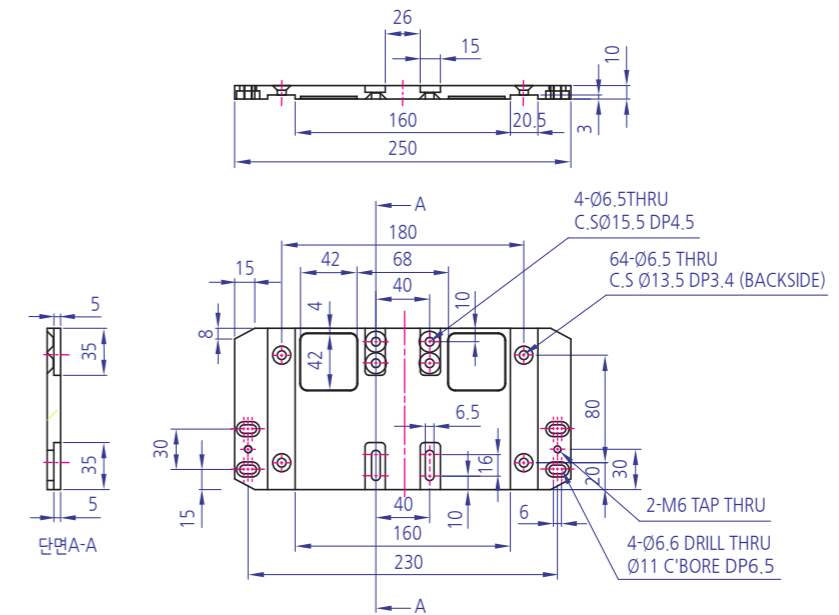

### YKBK-D-379.5x270x64.69

AL BRACKET

Material ALDC12

Surface Processing 액체도장(SILVER)

Application N2\_RACK

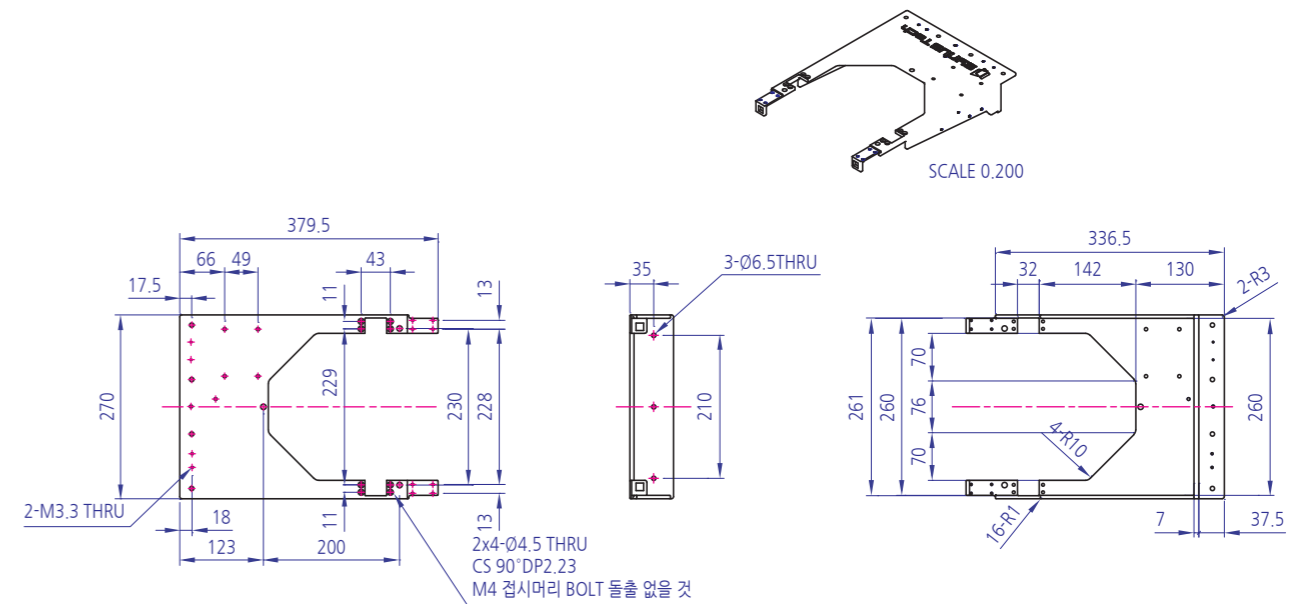

**YKBK-D90-1L(ROLLER BKT(L,R))**

AL BRACKET

Material ALDC12

Surface Processing 실버도장

Application ROLLER BKT



Code : YKBK-D90-1L  
Code : YKBK-D90-1R

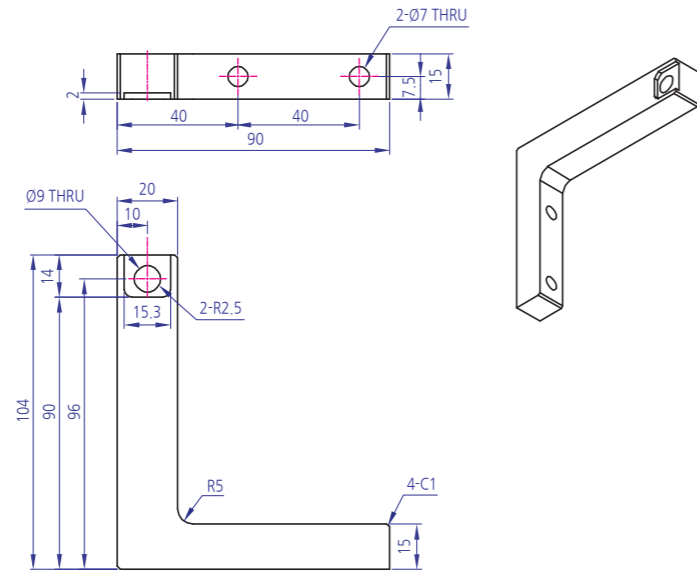

**YKBK-D100-1(RACEWAY JOINT PLATE)**

AL BRACKET

Material ALDC12

Surface Processing 실버도장

Application RACEWAY JOINT PLATE

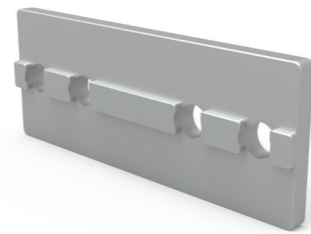

Code : YKBK-D100-1

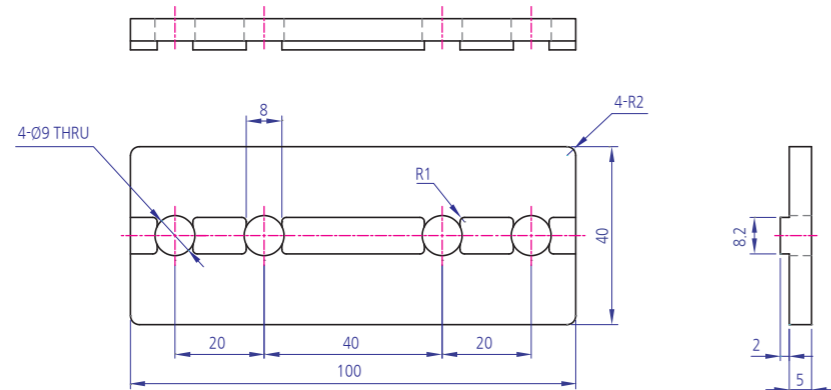

Code : YKBK-DCJ30SV

**YKBK-DCJ30SV(CORNER JOINT)**

AL BRACKET

Material ALDC12

Surface Processing SILVER도장

Application CORNET JOINT 3030

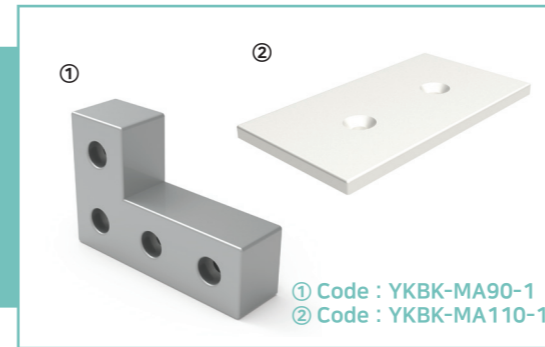
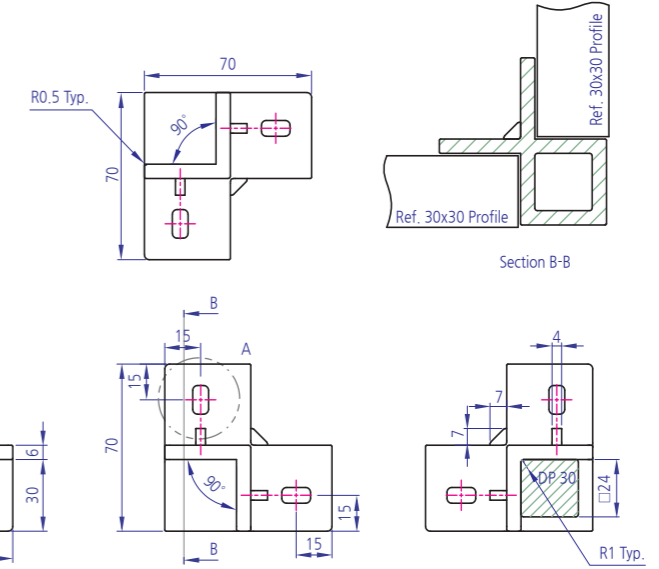
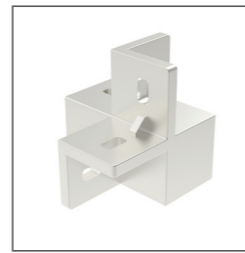

① Code : YKBK-MA90-1  
② Code : YKBK-MA110-1

**YKBK-MA90-1/YKBK-MA110-1(ENDCAP)**

AL BRACKET

Material ALDC12

Surface Processing 분체도장(T-SILVER)

Application JOINT BRACKET / ENDCAP

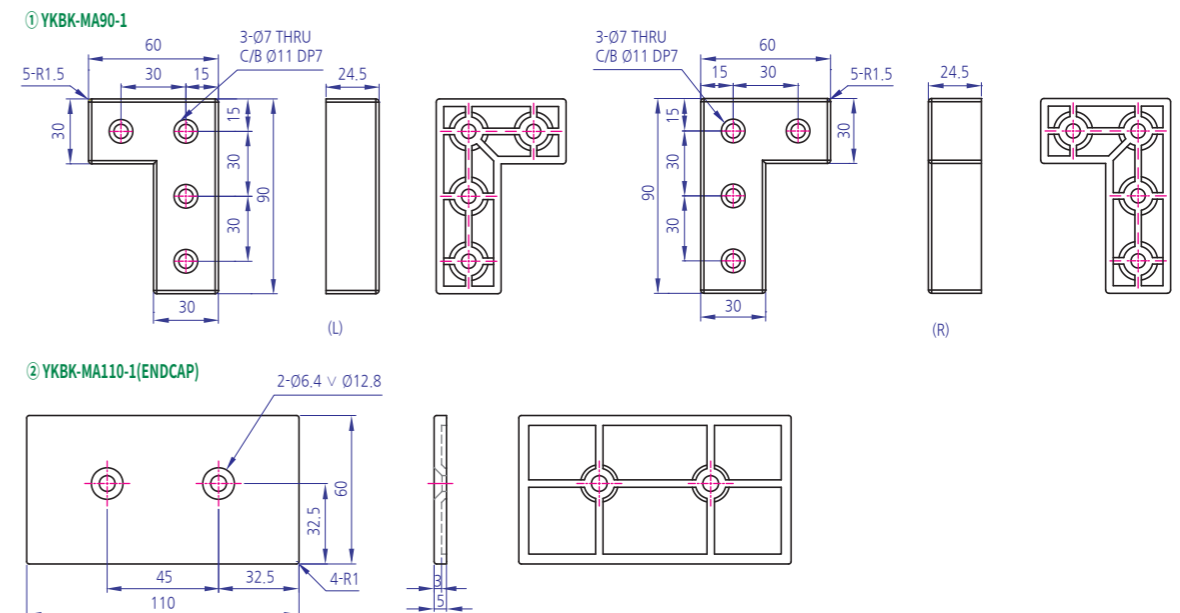



**YKBK-M-CS-D30**  
CUSHION DOOR

Material 우레탄  
Surface Processing SANDING(IVORY)  
Application 충격흡수용(도어용)



Code : YKBK-ECD30-1

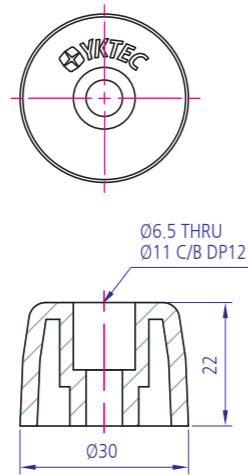

**YKBK-M-CS-50x30x30**  
CUSHION DOOR

Material 우레탄  
Surface Processing SANDING(IVORY)  
Application 충격흡수용(도어용)

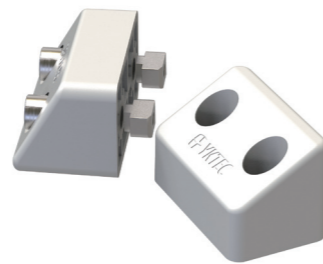

Code : YKBK-ECQ50-1

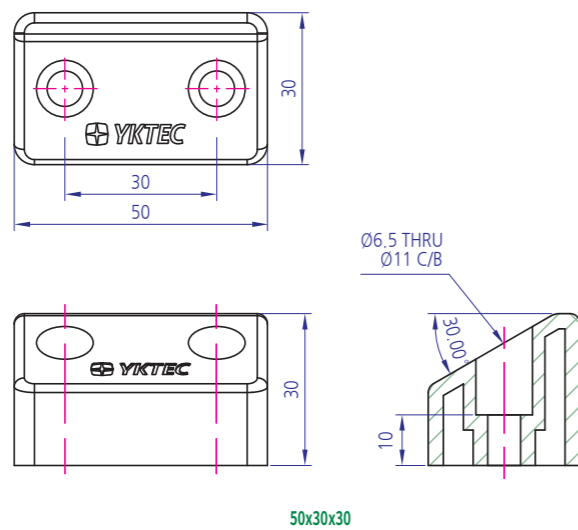

50x30x30



Code : YKBK-MC6520L  
Code : YKBK-MC6520R

**YKBK-AT65x20**  
TOP COVER SPACER

Material ACETAL  
Surface Processing WHITE(백색)  
Application 2035 도어용

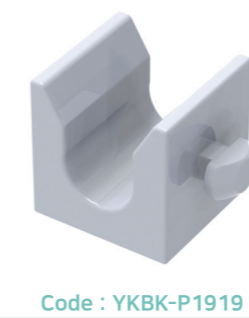
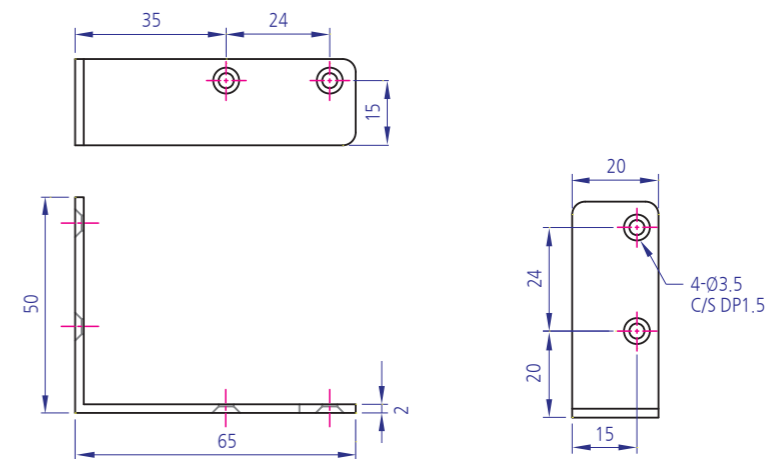

Code : YKBK-P1919

**YKBK-P19.5x19.5x19**  
PIPE BRACKET

Material NYLON+GF  
Surface Processing NATURAL  
Application PIPE BRACKET

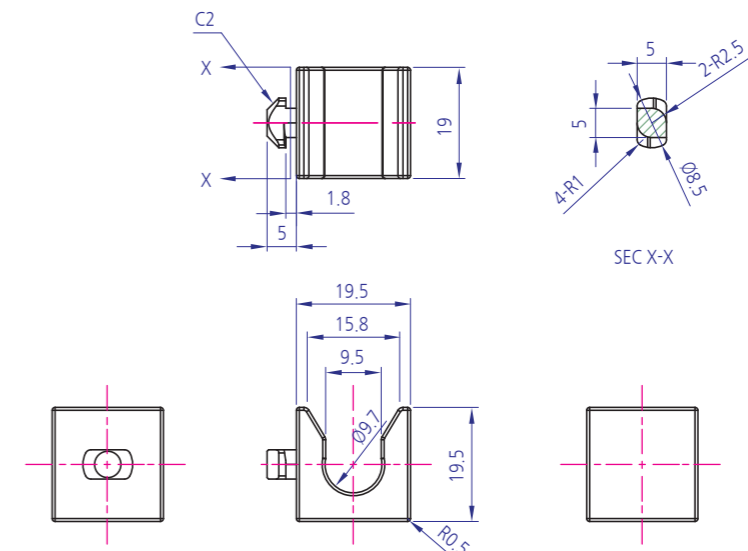

**YKBK-Ø26x9**  
PC BRACKET

Material PC ALLOY  
Surface Processing BLACK(흑)  
Application 서포터 브라켓



Code : YKBK-M26-1B

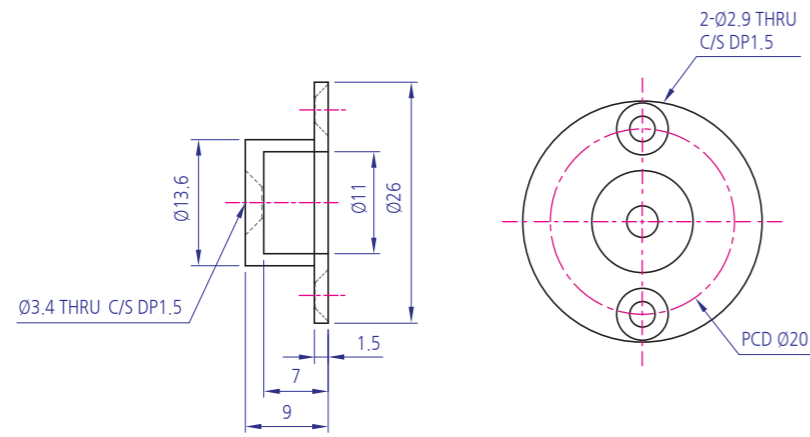

**YKBK-45x60x185**  
PC BRACKET

Material PC ALLOY  
Surface Processing BLACK(흑)  
Application 서포터 브라켓



Code : YKBK-M45-1B

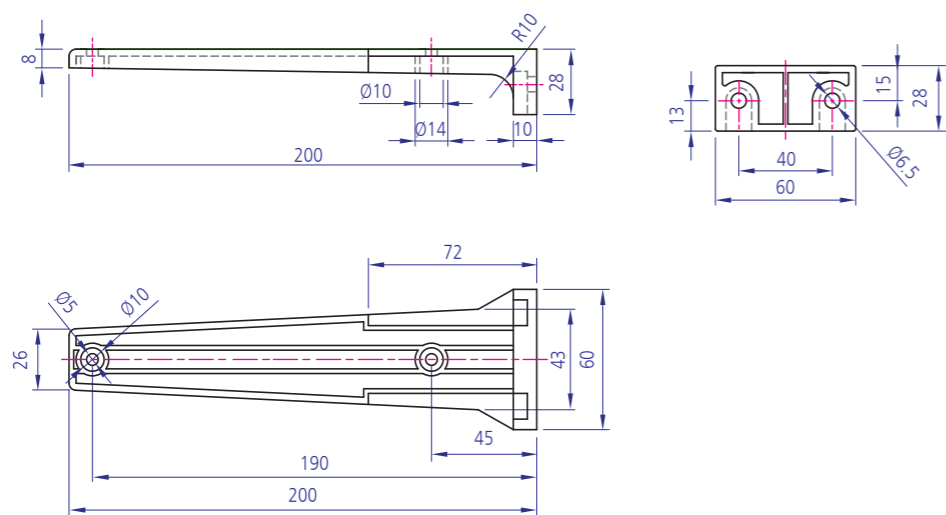

Code : YKBK-PMA5414

**YKBK-54x14.5x8.5**  
ACETAL BRACKET

Material ACETAL  
Surface Processing BLACK(흑)  
Application CARD STOPPER

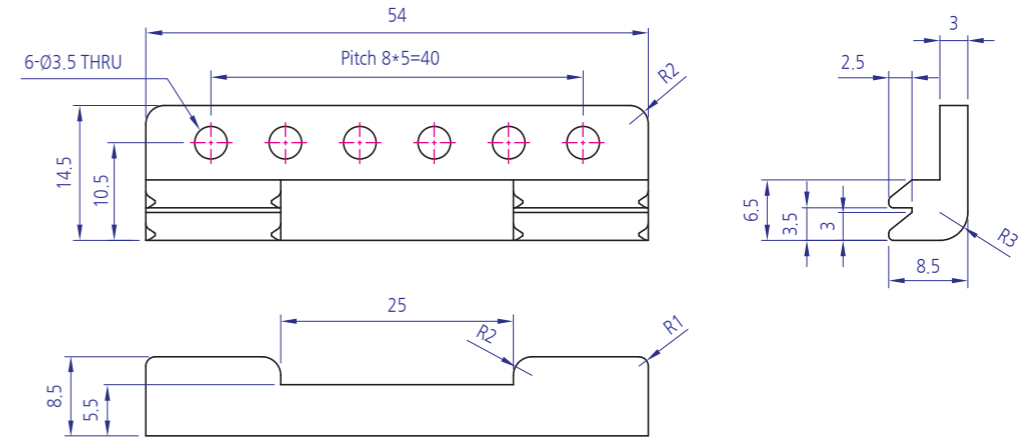

Code : YKBK-M64-1B

**YKBK-M64x45x30**  
PC BRACKET

Material PA6 GF30  
Surface Processing BLACK(흑)  
Application ROLLER

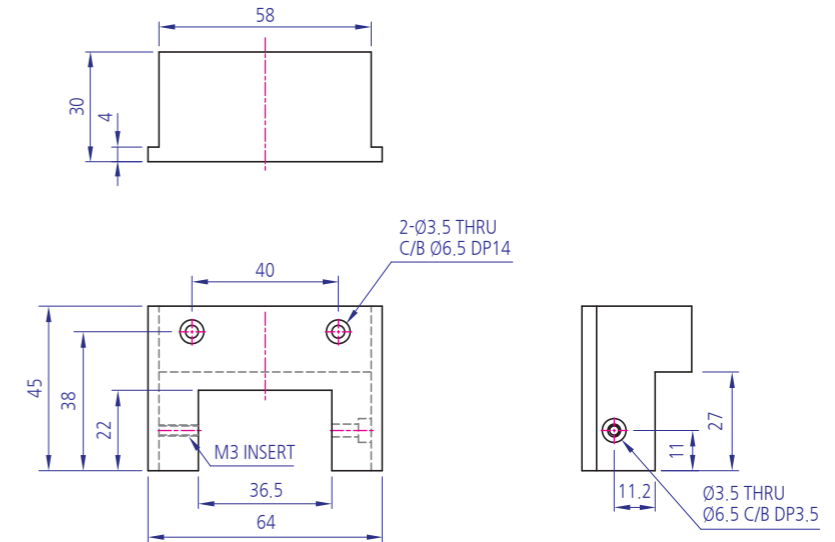

Roller  
Bearing Holder  
Motor Base  
Bracket  
Multi Block  
Joint  
Hinge  
Magnet  
Handle  
Foot Base  
방진구  
Leveling Foot  
Cover  
End Cap  
Bolt  
Nut  
Washer  
Special  
Profile  
Caster

Roller  
Bearing Holder  
Motor Base  
Bracket  
Multi Block  
Joint  
Hinge  
Magnet  
Handle  
Foot Base  
방진구  
Leveling Foot  
Cover  
End Cap  
Bolt  
Nut  
Washer  
Special  
Profile  
Caster

**YKBK-M-137x68x20\_SLS**  
AL BRACKET

Material PVC, 대전방지  
Surface Processing GRAY ,BLACK(대전방지)  
Application Guide Roller suport/Buffer BKT



Code : YKBK-M137-1

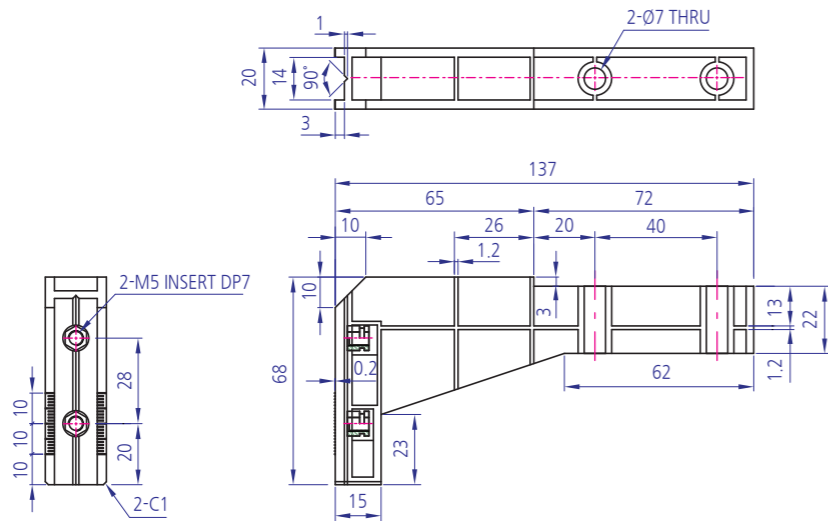

**YKBK-DC AV 15x20-12T**  
AL BRACKET(CLAMP)

Material ALDC-12  
Surface Processing SILVER(SHOT,액체도장)  
Application 프로파일용 연결부품



Code : YKBK-DAV1520A

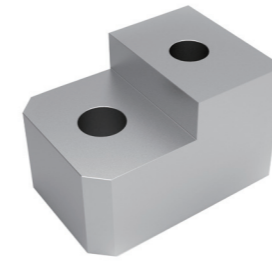
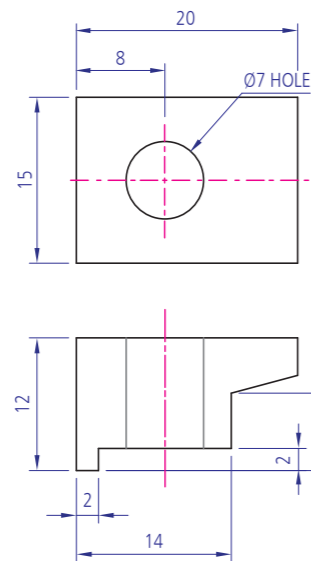

Code : YKBK-DSF16-1S

**YKBK-DC SF16x25-15T**  
AL BRACKET(CLAMP)

Material ALDC-12  
Surface Processing SILVER(Shot,액체도장)  
Application P/C복합판 고정용 (가이드 블럭)

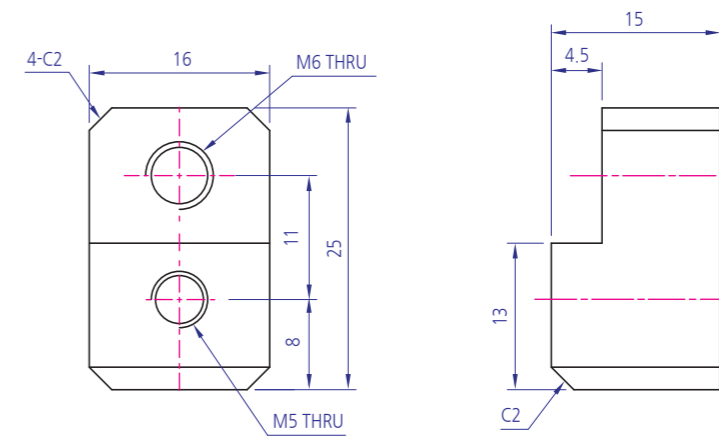

**YKBK-DC 20.5x8x15**  
AL BRACKET(CLAMP)

Material ALDC-12  
Surface Processing SILVER도장  
Application 부품 고정용



Code : YKBK-AE20-1

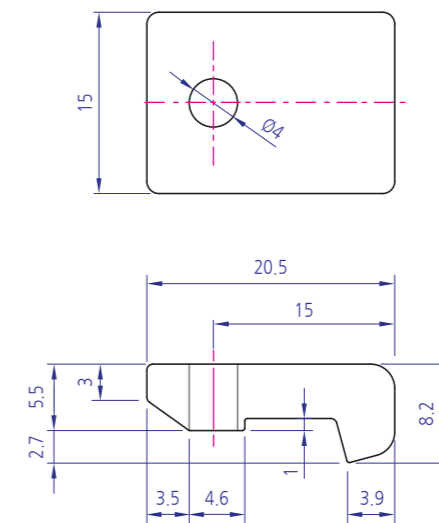





Roller  
Bearing Holder  
Motor Base  
Bracket  
Multi Block  
Joint  
Hinge  
Magnet  
Handle  
Foot Base  
방진구  
Levelling Foot  
Cover  
End Cap  
Bolt  
Nut  
Washer  
Special  
Profile  
Caster

Roller  
Bearing Holder  
Motor Base  
Bracket  
Multi Block  
Joint  
Hinge  
Magnet  
Handle  
Foot Base  
방진구  
Levelling Foot  
Cover  
End Cap  
Bolt  
Nut  
Washer  
Special  
Profile  
Caster

**YKBK-AL-CLAMP 45x36**  
AL BRACKET(CLAMP)

Material A6061  
Surface Processing SILVER ANODIZING  
Application 주문사양

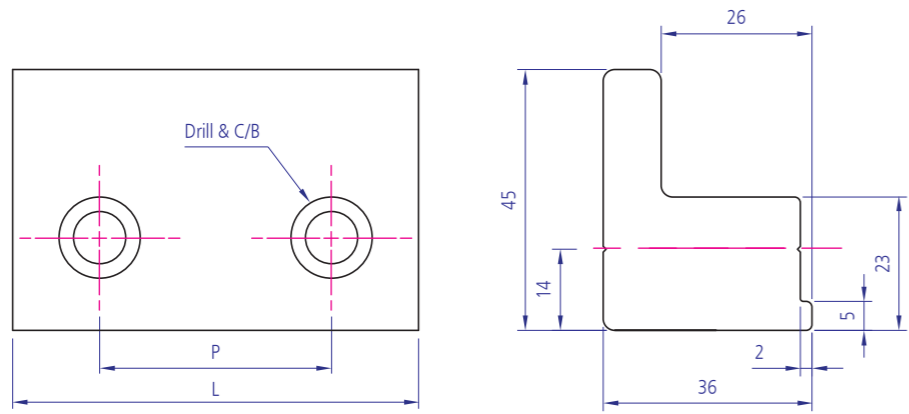

**YKBK-AL-CLAMP 45x36-1**  
AL BRACKET(CLAMP)

Material A6061  
Surface Processing SILVER ANODIZING  
Application 주문사양

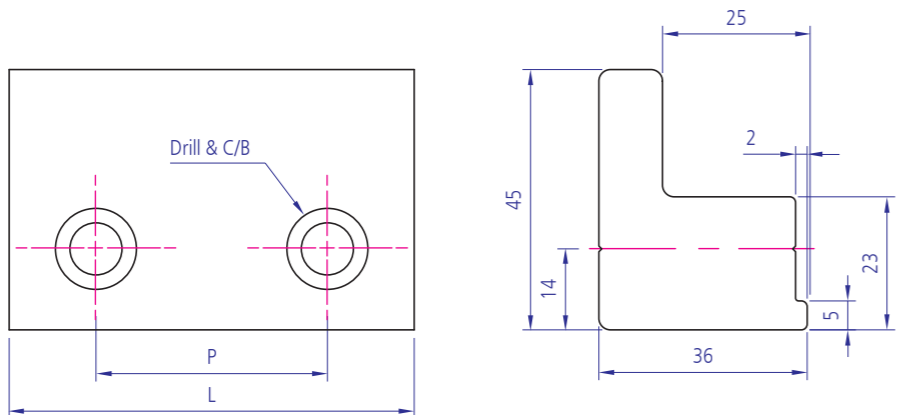

**YKBK-AL-CLAMP 49x42**  
AL BRACKET(CLAMP)

Material A6061  
Surface Processing SILVER ANODIZING  
Application 주문사양

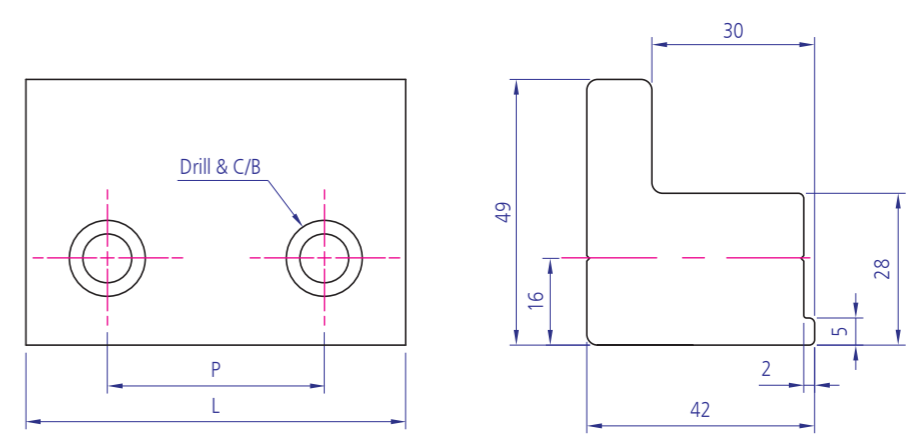

**YKBK-AL-CLAMP 49x42-1**  
AL BRACKET(CLAMP)

Material A6061  
Surface Processing SILVER ANODIZING  
Application 주문사양

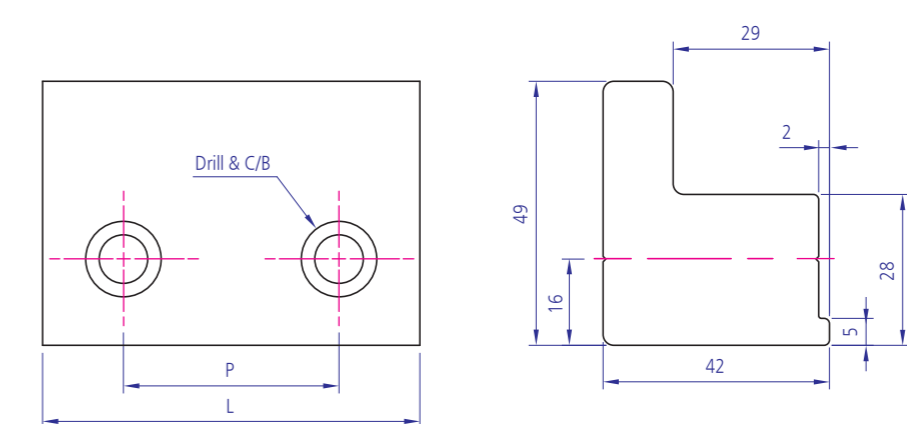

**YKBK-AL-CLAMP 54x32**

AL BRACKET(CLAMP)

Material A6061

Surface Processing SILVER ANODIZING

Application 주문사양

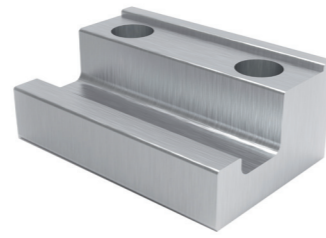

Code : YKCL-A5432

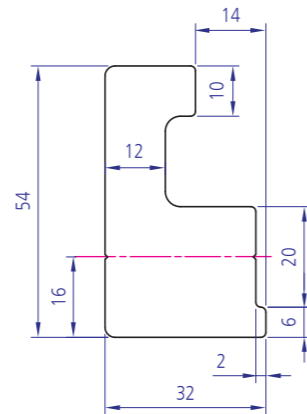
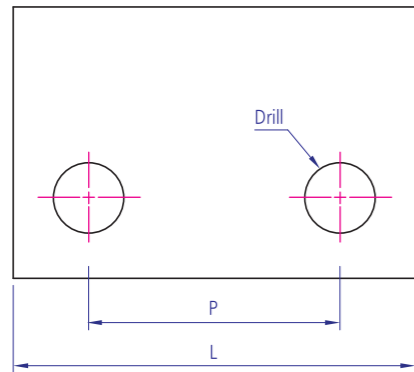

**YKBK-AL 60x21.5xL**

AL BRACKET(CLAMP)

Material A6061

Surface Processing SILVER ANODIZING

Application 주문사양

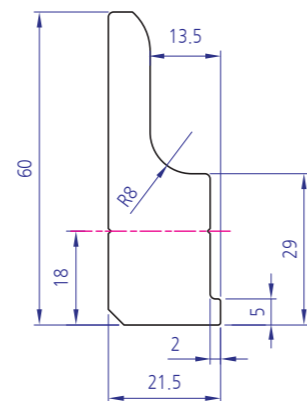
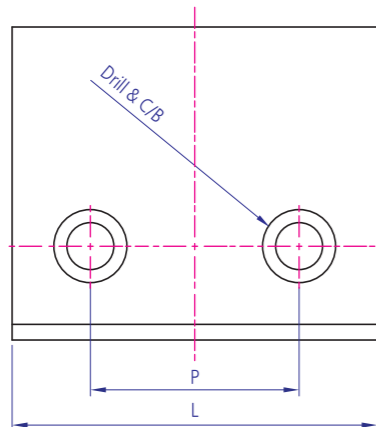
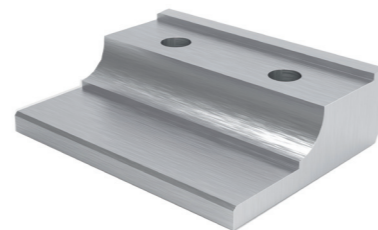

**YKBK-AL-CLAMP 98x42**

AL BRACKET(CLAMP)

Material A6061

Surface Processing SILVER ANODIZING

Application 주문사양

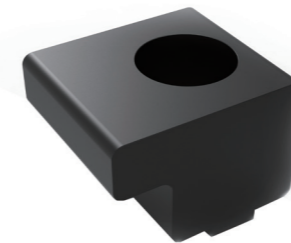
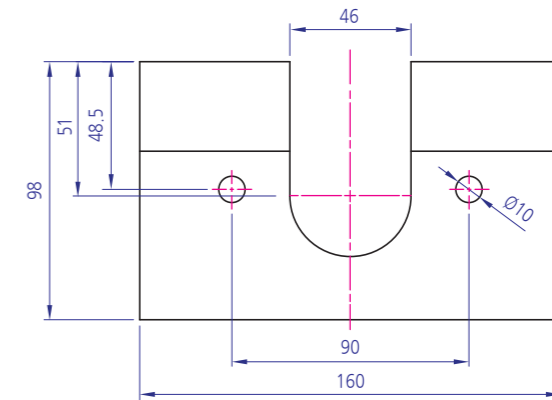
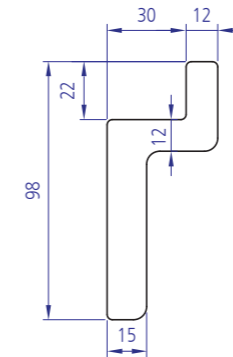

**YKBK-P15x17x13**

PC BRACKET

Material PC+GF30

Surface Processing BLACK

Application 케이블서포터 고정용

Code : YKCL-EV151713B

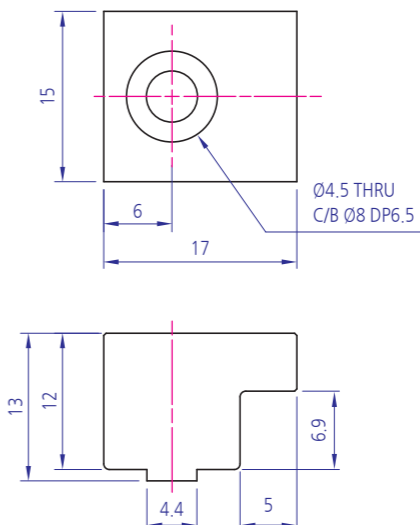

**YKBK-P15x21x13**  
PC BRACKET

Material PC+GF30  
Surface Processing BLACK  
Application 케이블 서포터 고정용

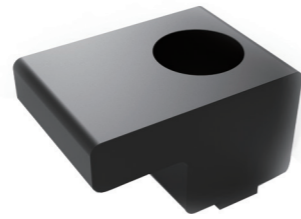

Code : YKCL-EV152113B

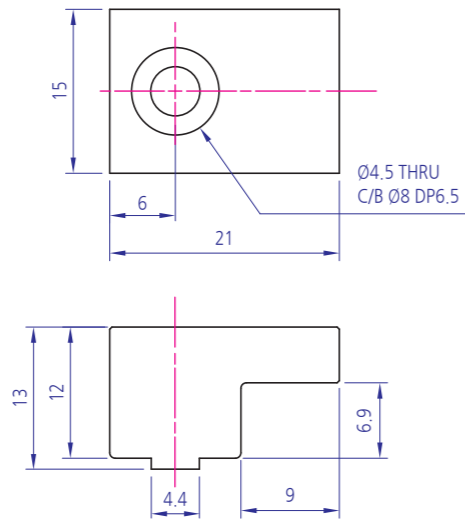

**YKBK-CT 42.5x35x24**  
CASTING CLAMP

Material GCD450(Steel 주물)  
Surface Processing Zn(White)  
Application RAIL 고정용



Code : YKCL-CT42-1ZW

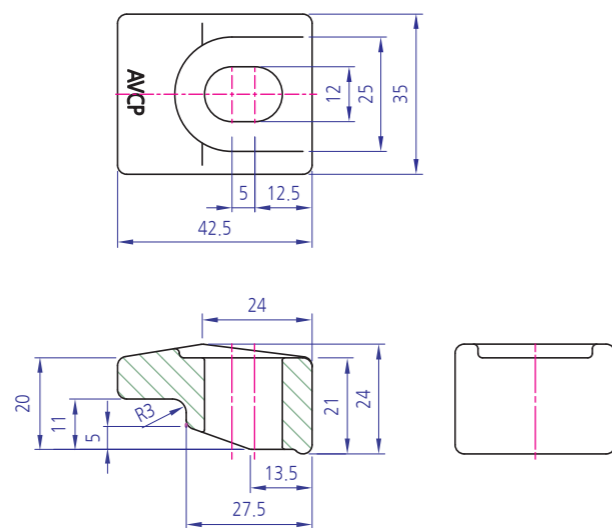

Code : YKCL-CT54-1ZW

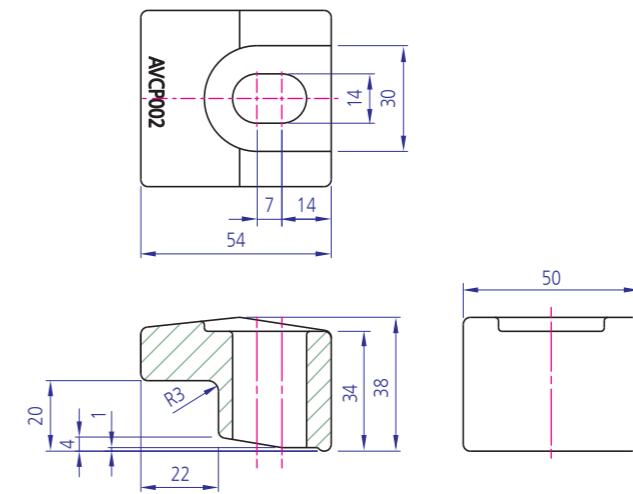

**YKBK-CT 54x50x38**  
CASTING CLAMP

Material GCD450(Steel 주물)  
Surface Processing Zn(White)  
Application RAIL 고정용



Code : YKBK-CT404-1S

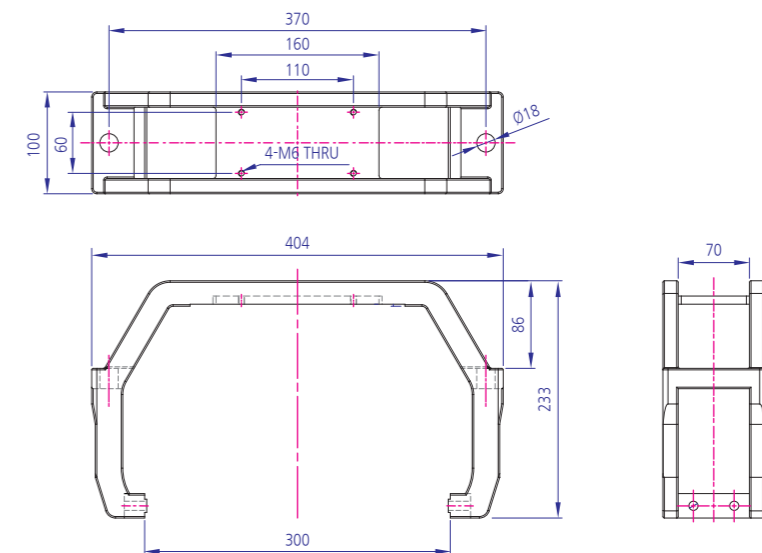

**YKBK-DC 404x233x100**  
W HANGER

Material ALDC12  
Surface Processing 액체도장(SILVER)  
Application OHCV용

**YKBK-D-423x248x110**  
W HANGER

Material ALDC12  
Surface Processing 액체도장(SILVER)  
Application OHCV용



Code : YKBK-CT423-1S

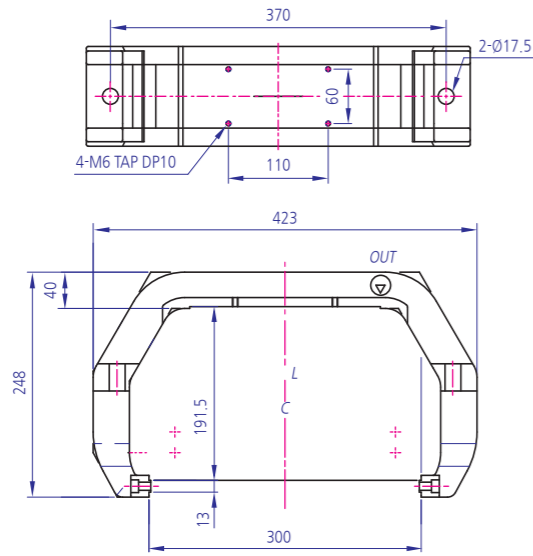

**YKBK-D-503x273x110 SFA**  
W HANGER

Material ALDC12  
Surface Processing 액체도장(SILVER,SHOT)  
Application OHCV용



Code : YKBK-CT503-1S

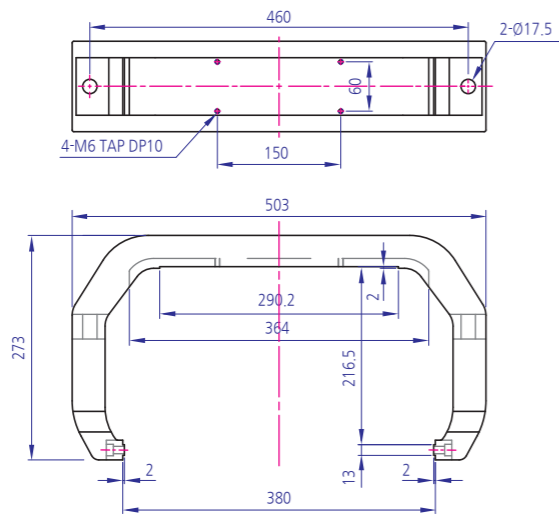

Code : YKBK-SH400-1

**YKBK-DC 400x405x35**  
W HANGER

Material ALDC12  
Surface Processing 무정전도장(White gray)  
Application SHELF용

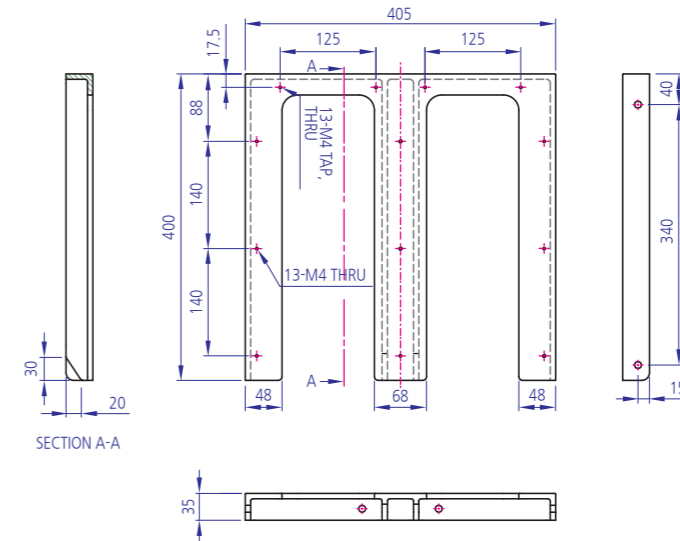

Code : YKBK-SH860-1

**YKBK-D-SHELF-860 SFA**  
W HANGER

Material ALDC12  
Surface Processing 우레탄 대전방지 도장(white gray)  
Application SHELF용

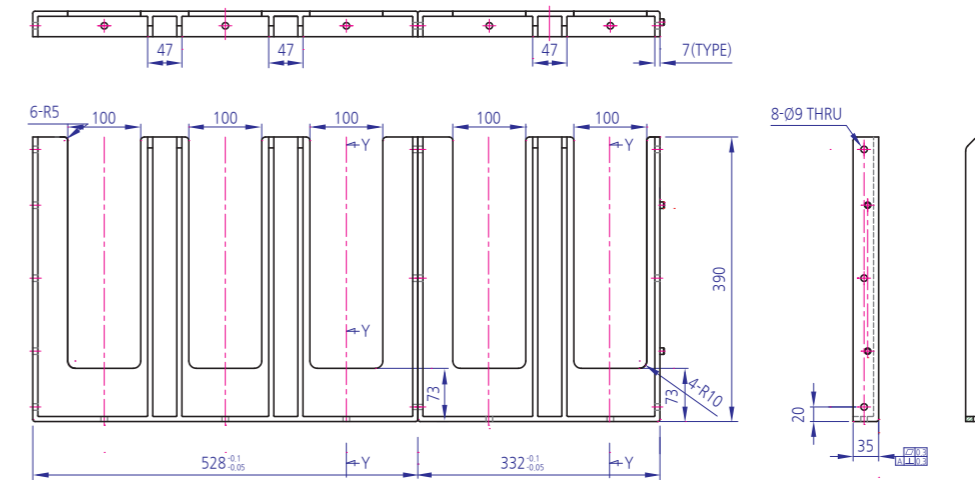



**YKBK-D-SHELF-528 SFA**  
AL BRACKET

Material ALDC12  
Surface Processing 우레탄 대전방지 도장(white gray)  
Application SHELF용

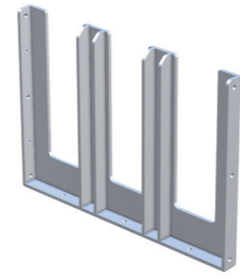

Code : YKBK-SH528-1

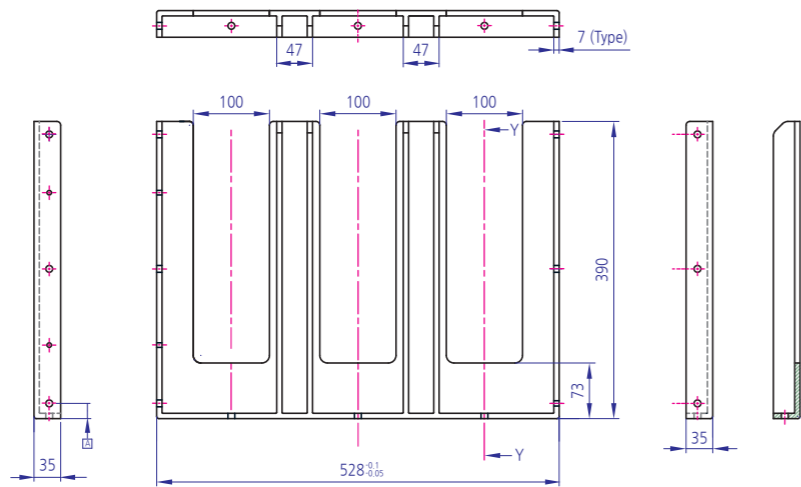

**YKBK-D-SHELF-332 SFA**  
AL BRACKET

Material ALDC12  
Surface Processing 무정전도장(White gray)  
Application SHELF용

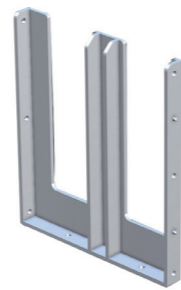

Code : YKBK-SH332-1

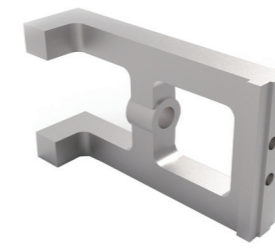
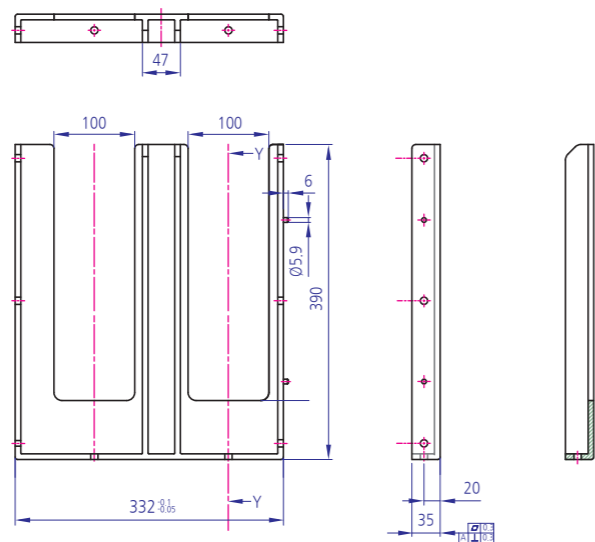

Code : YKBK-CT115-1S

**YKBK-CT 115x194.5x52**  
CASTING BRACKET

Material SC480(주물)  
Surface Processing SILVER도장  
Application OHCV용

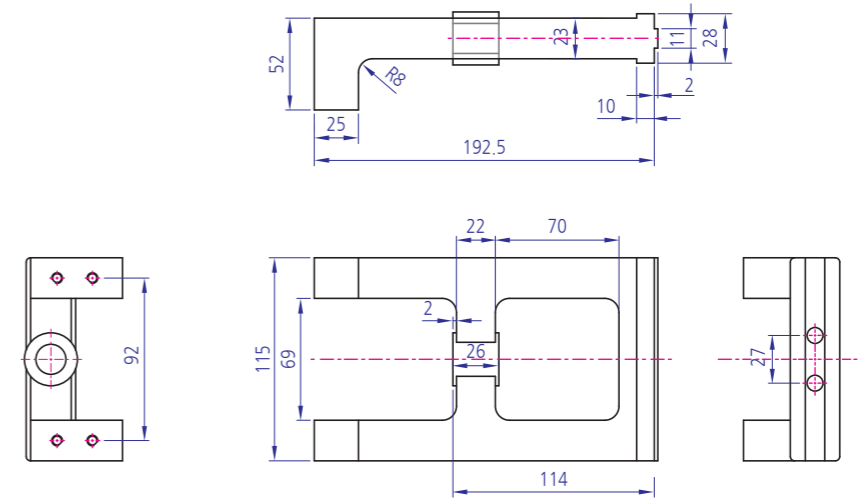

**YKBK-C-115x167x52**  
CASTING BRACKET

Material SC480(주물)  
Surface Processing SILVER도장  
Application OHCV용



Code : YKBK-CT115-2S

**YKBK-C-115x167x52**  
CASTING BRACKET

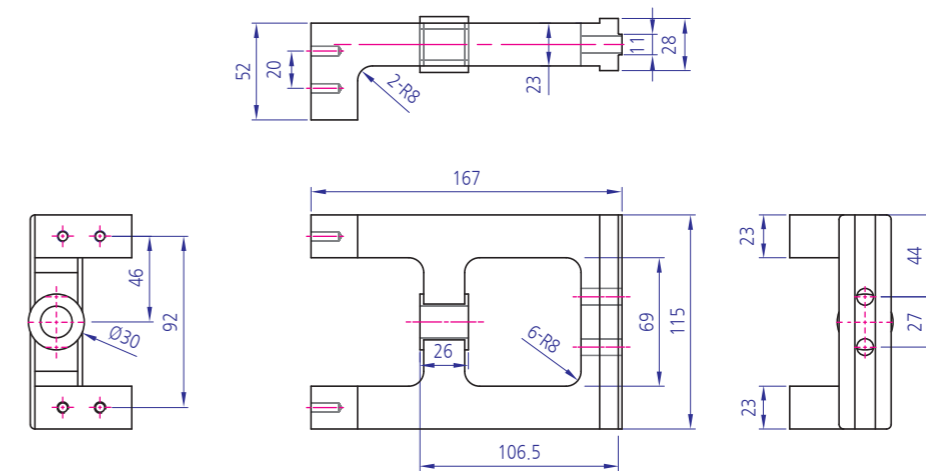

**YKBK-C-392x191x90**  
CASTING BRACKET

Material FCD45(주물)  
Surface Processing SILVER도장  
Application OHCV용



Code : YKBK-CT392-1S

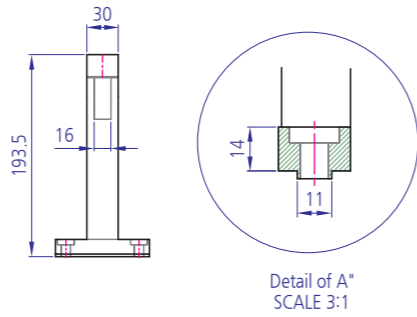
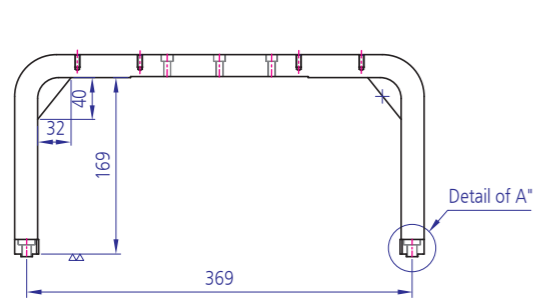
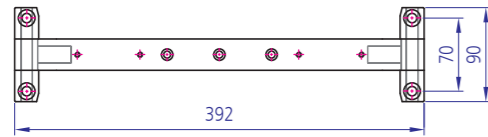

**YKBK-CT 393x253.5x70**  
CASTING BRACKET

Material FCD45(주물)  
Surface Processing SILVER도장  
Application OHCV용



Code : YKBK-CT393-1S

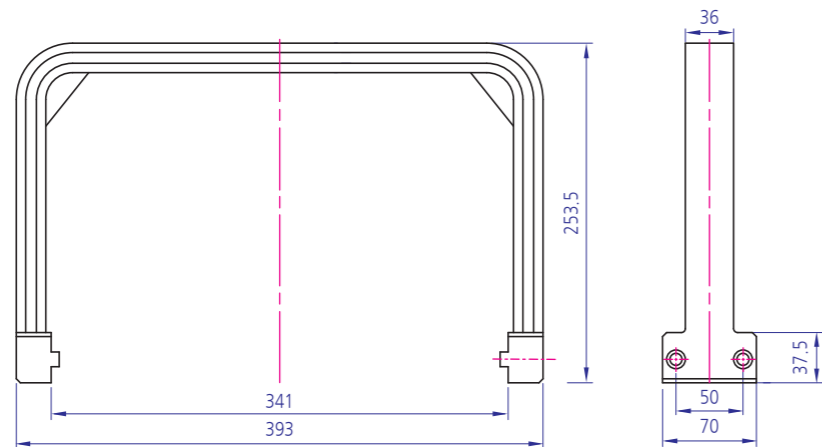

Code : YKBK-CT393-2S

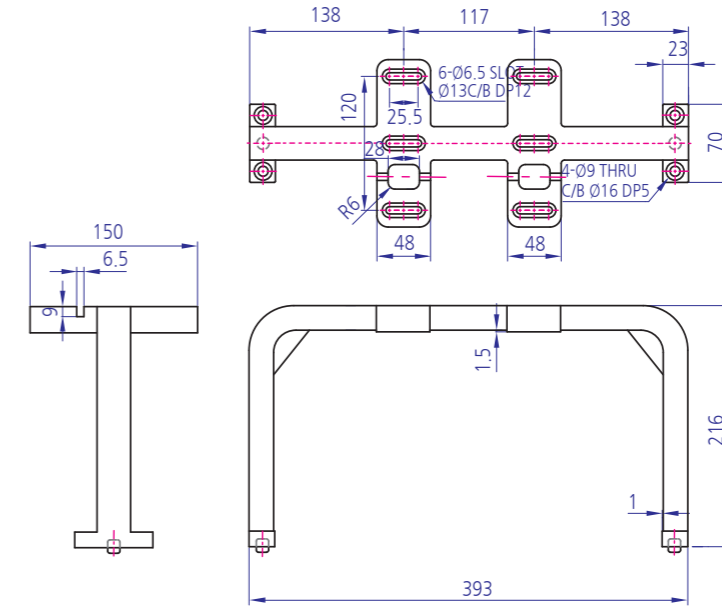

**YKBK-CT 393x216x150**  
CASTING BRACKET

Material FCD45(주물)  
Surface Processing SILVER도장  
Application OHCV용

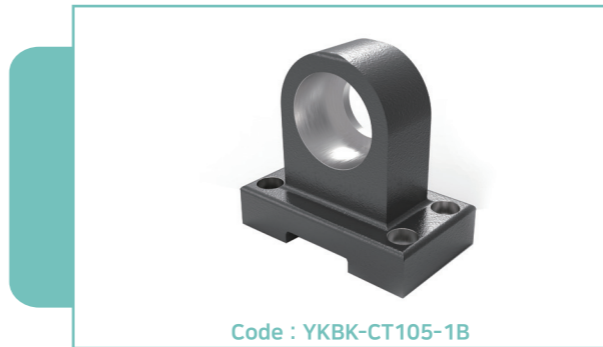

Code : YKBK-CT105-1B

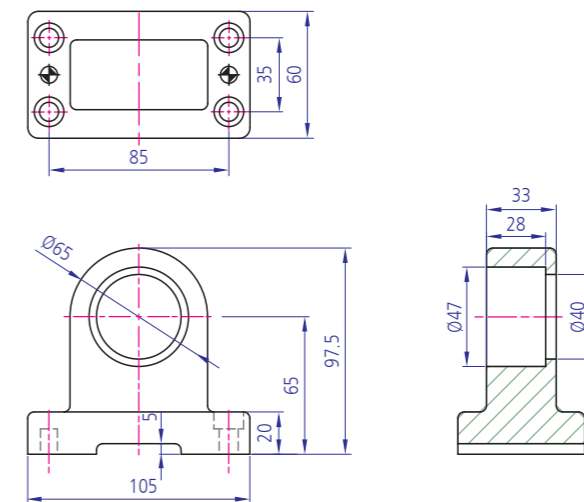

**YKBK-C-105x97.5x60**  
BRACKET 주물제품

Material FCD45(주물)  
Surface Processing 분체도장(흑)  
Application CARRIAGE용/ FIX HINGE BLOCK-4

**YKBK-C-105x122x60**

BRACKET 주물제품

Material FCD45(주물)

Surface Processing 분체도장(흑)

Application CARRIAGE용/ FIX HINGE BLOCK

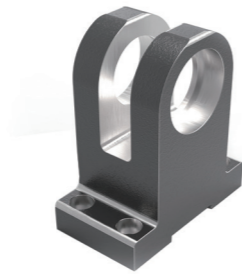

Code : YKBK-CT105-2B

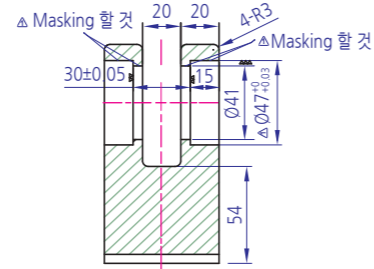
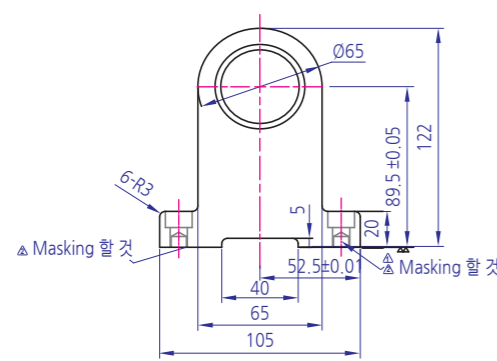
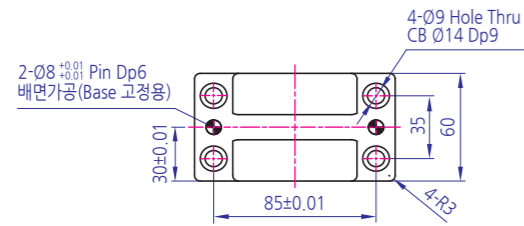

**YKBK-C-130x121x69**

BRACKET 주물제품

Material FCD45(주물)

Surface Processing 분체도장(흑)

Application CARRIAGE용/ FIX HINGE BLOCK-2

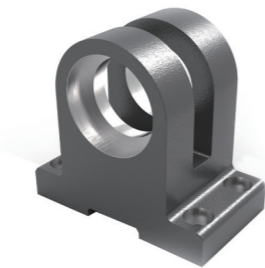

Code : YKBK-CT130-1-1B

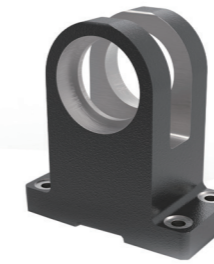
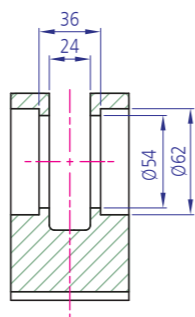
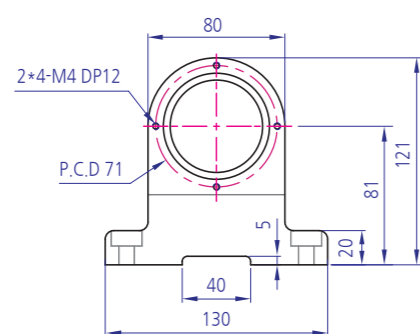
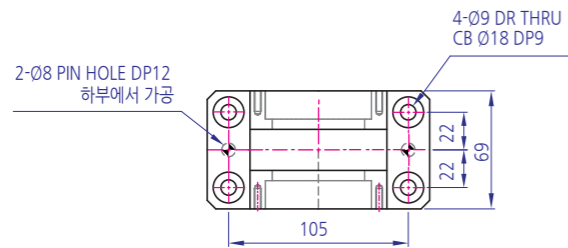

Code : YKBK-CT130-2AB  
Code : YKBK-CT130-2BB

**YKBK-C-130x144x69**

BRACKET 주물제품

Material FCD45(주물)

Surface Processing 분체도장(흑)

Application CARRIAGE용/ FIX HINGE BLOCK-1

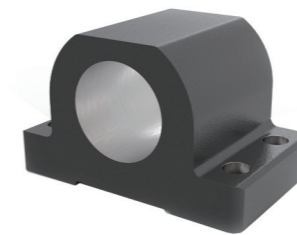
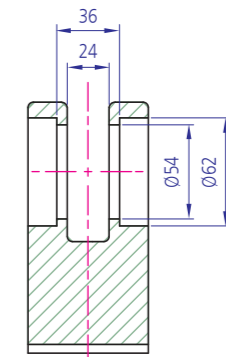
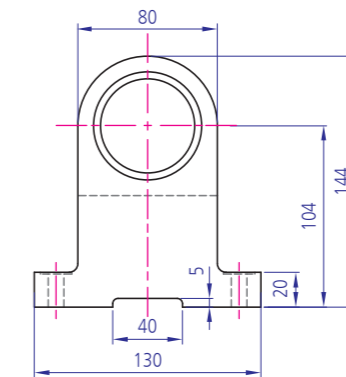
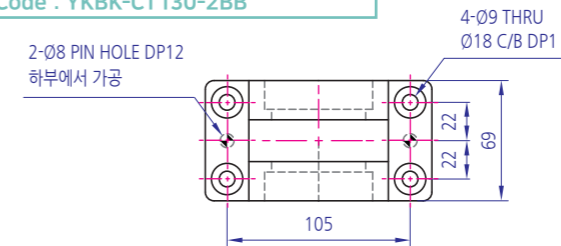

Code : YKBK-CT140-1B

**YKBK-C-140x87x85**

BRACKET 주물제품

Material FCD45(주물)

Surface Processing 분체도장(흑)

Application CARRIAGE용 /BALL SCREW HOUSING

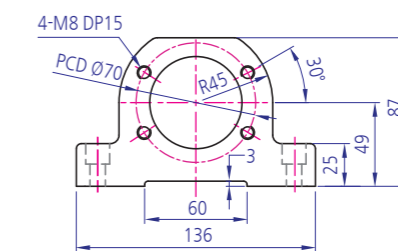
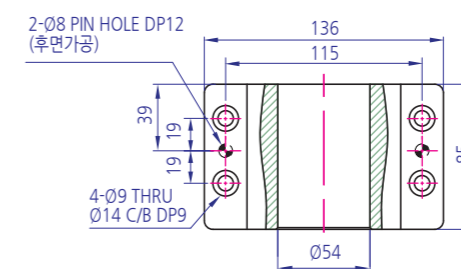

**YKBK-C-180x130x110**

BRACKET 주물제품

Material FCD45(주물)

Surface Processing 분체도장(흑)

Application CARRIAGE용 /MOVING HINGE BLOCK

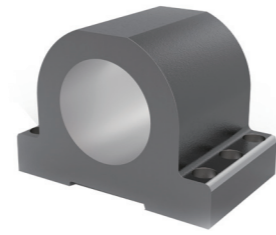

Code : YKBK-CT180-1-1B

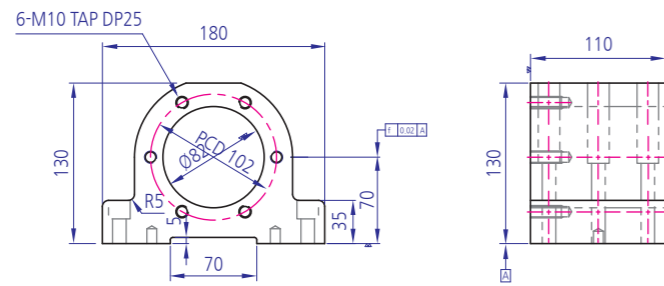
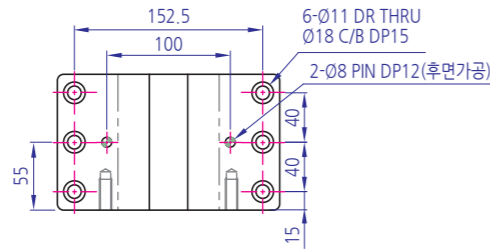

**YKBK-C-100x132x44**

BRACKET 주물제품

Material FDC450

Surface Processing BLACK(흑)

Application Ceiling SUPPORT



Code : YKBK-CT100-3S

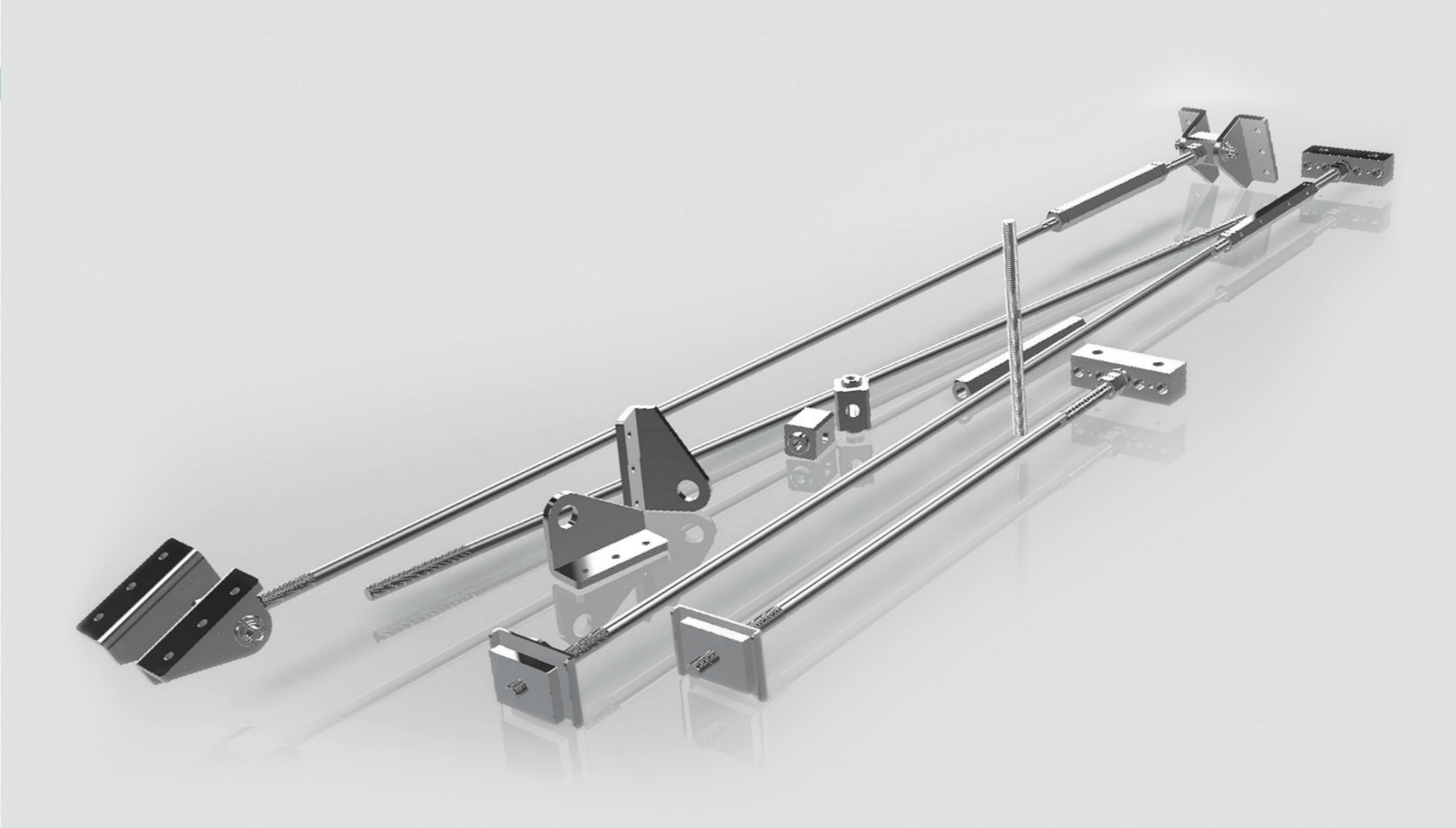
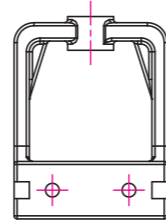
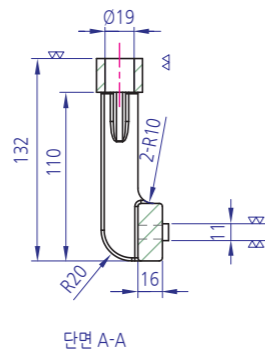
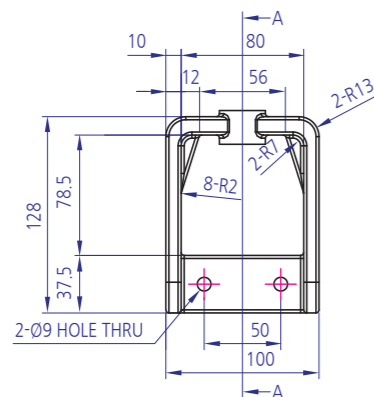
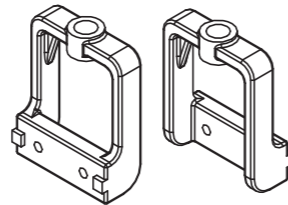
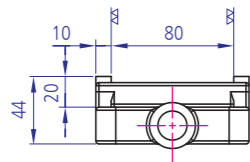

# HANGER SHAFT

Creating the Best Business Value

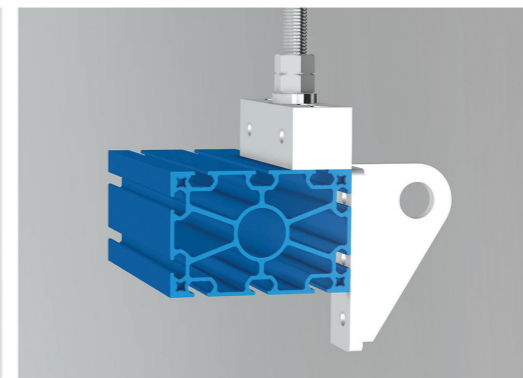
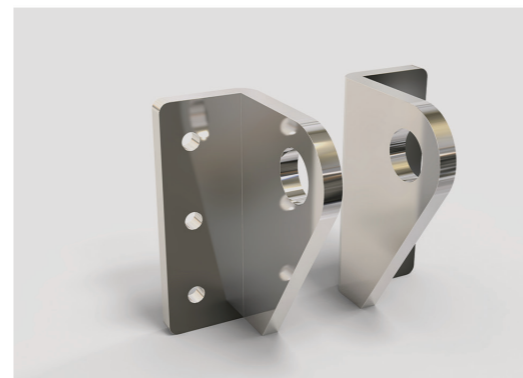
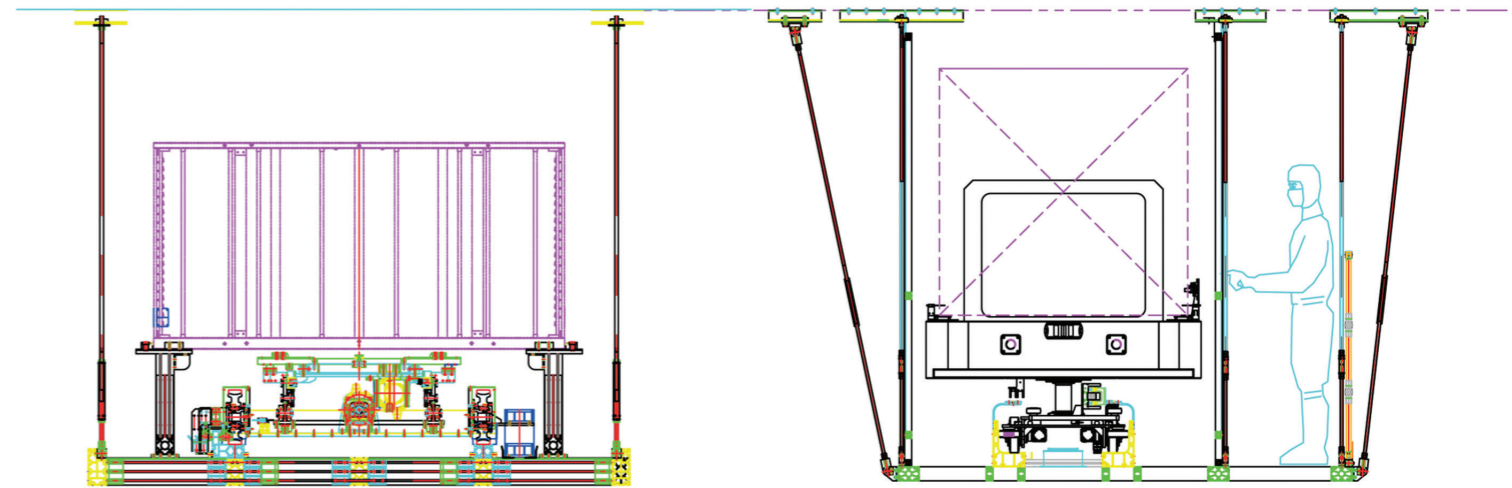



**BASE**  
HANGER SHAFT

Material SS400  
Surface Processing ENI(무전해니켈)  
Application HANGER SHAFT용

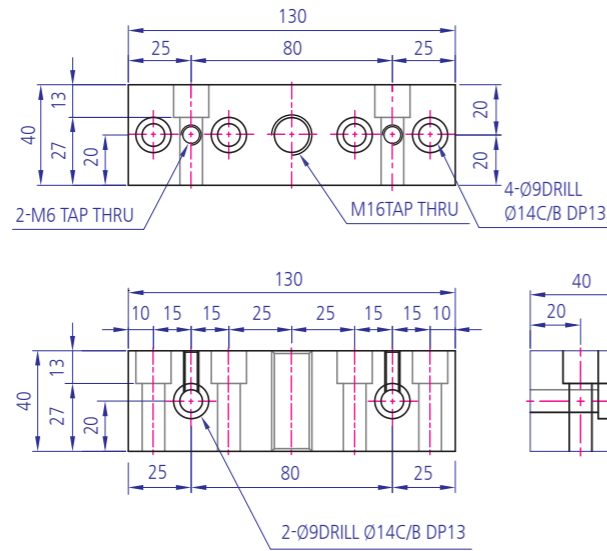

**BLOCK**  
HANGER SHAFT

Material SS400  
Surface Processing ENI(무전해니켈)  
Application HANGER SHAFT용

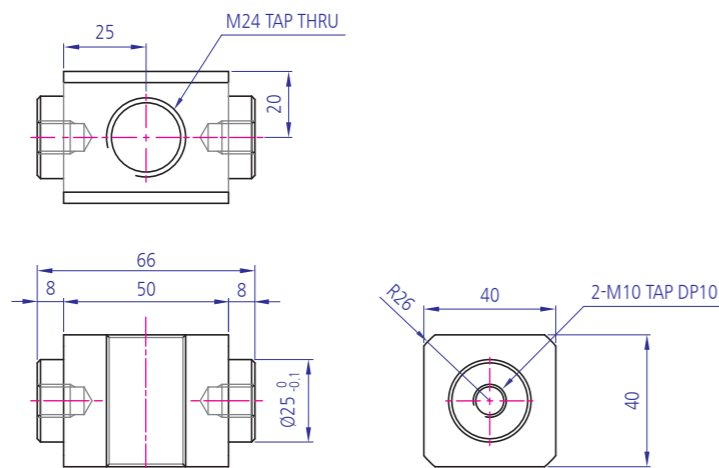
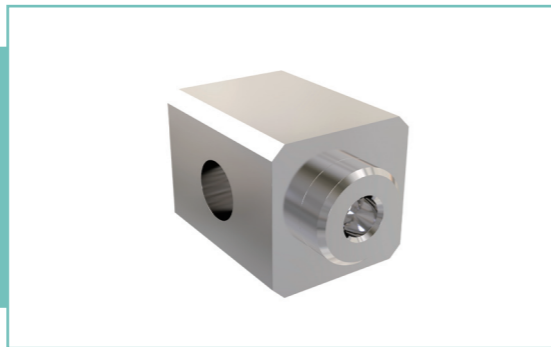

**BRACKET**  
HANGER SHAFT

Material SS400  
Surface Processing ENI(무전해니켈)  
Application HANGER SHAFT용

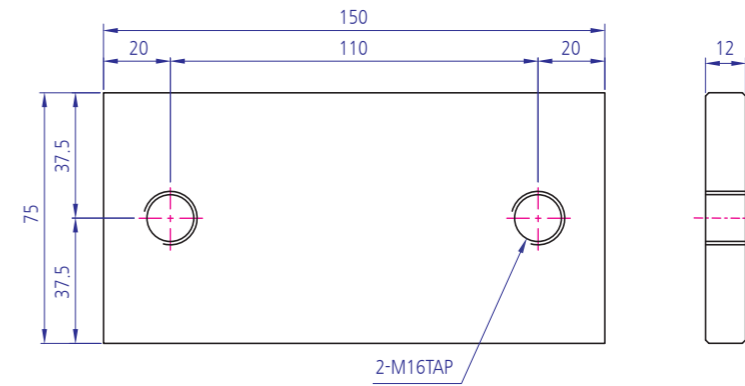

**C PLATE**  
HANGER SHAFT

Material SPHC  
Surface Processing ENI(무전해니켈)  
Application HANGER SHAFT용

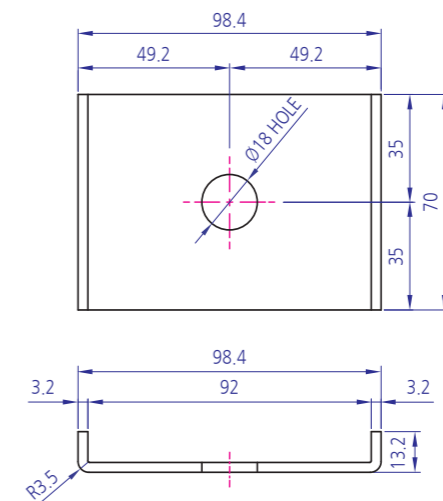

Roller  
Bearing Holder  
Motor Base  
Bracket  
Multi Block  
Joint  
Hinge  
Magnet  
Handle  
Foot Base  
방진구  
Leveling Foot  
Cover  
End Cap  
Bolt  
Nut  
Washer  
Special  
Profile  
Caster

Roller  
Bearing Holder  
Motor Base  
Bracket  
Multi Block  
Joint  
Hinge  
Magnet  
Handle  
Foot Base  
방진구  
Leveling Foot  
Cover  
End Cap  
Bolt  
Nut  
Washer  
Special  
Profile  
Caster



**HINGE L,R**  
HANGER SHAFT

Material SS400  
Surface Processing ENI(무전해니켈)  
Application HANGER SHAFT용

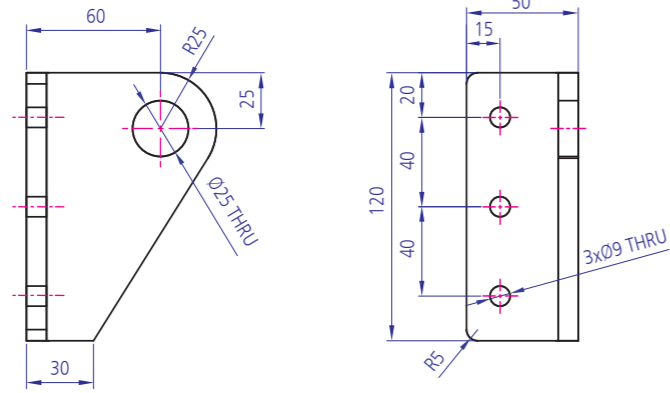

**PLATE**  
HANGER SHAFT

Material SS400  
Surface Processing ENI(무전해니켈)  
Application HANGER SHAFT용

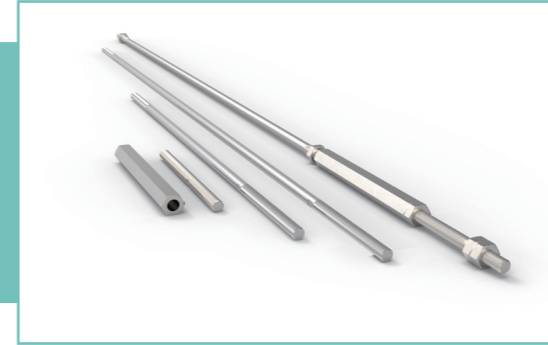
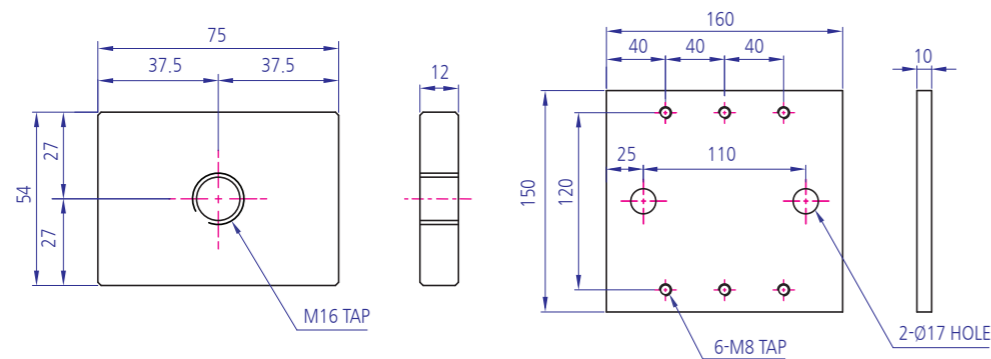

**SHAFT**  
HANGER SHAFT

Material S45C, SUS  
Surface Processing ENI(무전해니켈)  
Application HANGER SHAFT용 ASSY  
참고 다양한사이즈 사이즈 제작

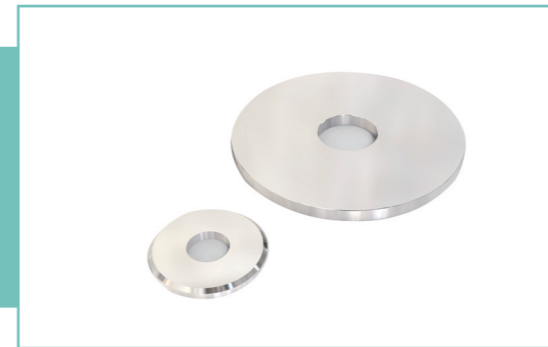
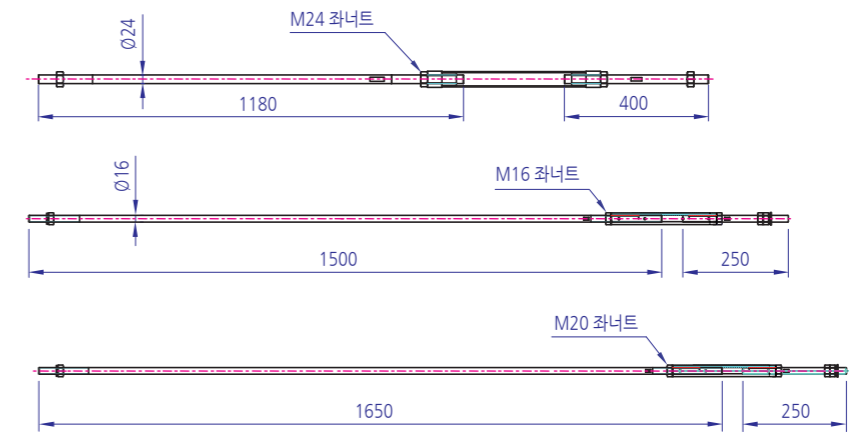

**WASHER**  
HANGER SHAFT

Material SPHC  
Surface Processing ENI(무전해니켈)  
Application HANGER SHAFT용

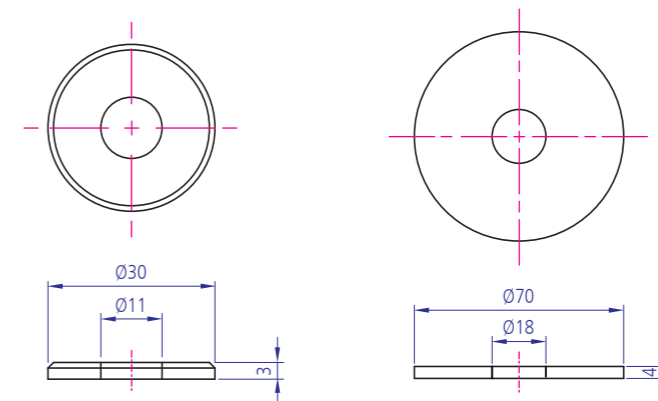

Roller  
 Bearing Holder  
 Motor Base  
**Bracket**  
 Multi Block  
 Joint  
 Hinge  
 Magnet  
 Handle  
 Foot Base  
 방진구  
 Levelling Foot  
 Cover  
 End Cap  
 Bolt  
 Nut  
 Washer  
 Special  
 Profile  
 Caster

Roller  
 Bearing Holder  
 Motor Base  
**Bracket**  
 Multi Block  
 Joint  
 Hinge  
 Magnet  
 Handle  
 Foot Base  
 방진구  
 Levelling Foot  
 Cover  
 End Cap  
 Bolt  
 Nut  
 Washer  
 Special  
 Profile  
 Caster

**YKB-TB-M16x100**  
HANGER SHAFT

Material SS400  
Surface Processing ENI(무전해니켈), 니켈  
Application HANGER SHAFT용  
참고 다양한사이즈 사이즈 제작

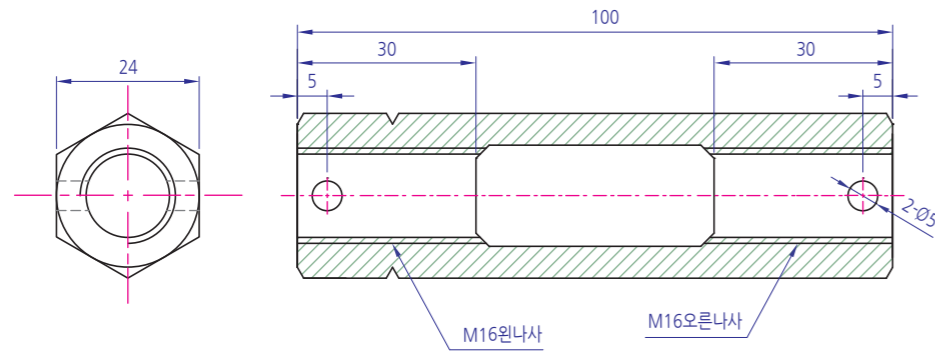

REFLECTOR PLATE  
**REFLECTOR PLATE 43x23x35**

**Technical Data**  
Material SUS  
Surface Processing  
Application REFLECTOR PLATE

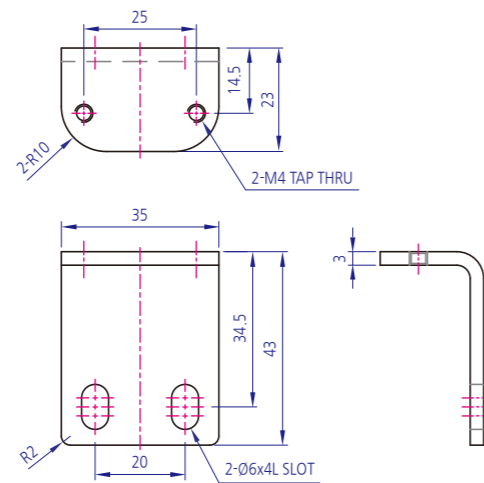

REFLECTOR PLATE  
**REFLECTOR PLATE 61x41x35**

**Technical Data**  
Material SUS  
Surface Processing  
Application REFLECTOR PLATE

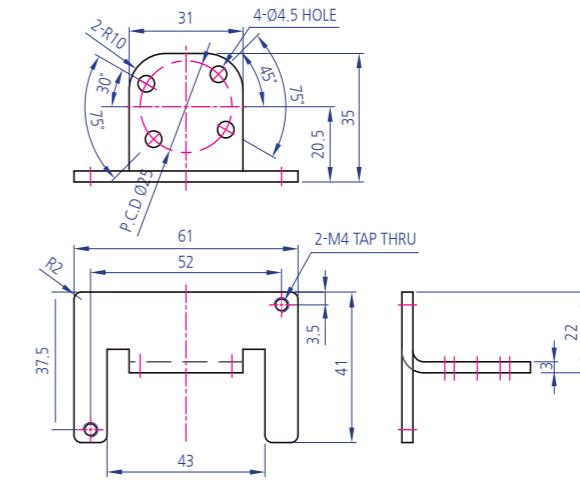

REFLECTOR PLATE  
**REFLECTOR PLATE 61x41x35**

**Technical Data**  
Material SUS  
Surface Processing  
Application REFLECTOR PLATE

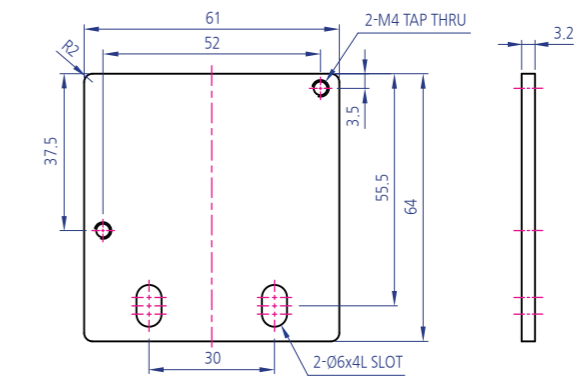

Roller  
Bearing Holder  
Motor Base  
Bracket  
Multi Block  
Joint  
Hinge  
Magnet  
Handle  
Foot Base  
방진구  
Leveling Foot  
Cover  
End Cap  
Bolt  
Nut  
Washer  
Special  
Profile  
Caster

Roller  
Bearing Holder  
Motor Base  
Bracket  
Multi Block  
Joint  
Hinge  
Magnet  
Handle  
Foot Base  
방진구  
Leveling Foot  
Cover  
End Cap  
Bolt  
Nut  
Washer  
Special  
Profile  
Caster



SENSOR BRACKET  
**SENSOR BKT 53x46x36**

**Technical Data**

**Material** SUS

**Surface Processing**

**Application** SENSOR BRACKET

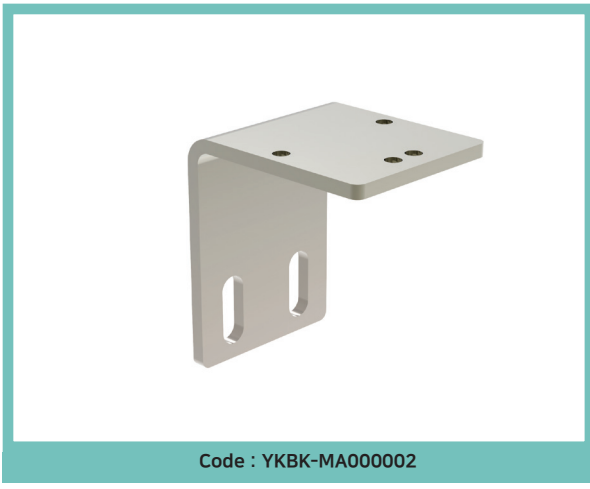
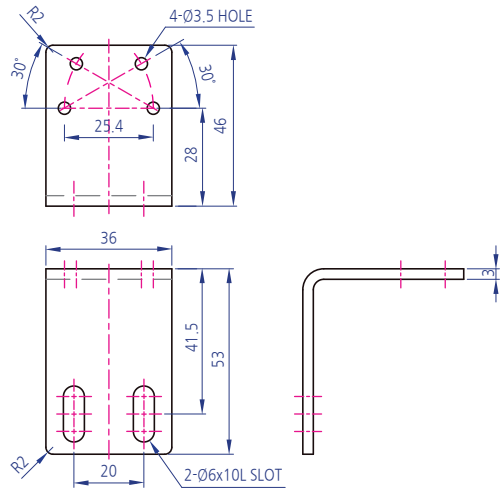

SENSOR BRACKET  
**SENSOR BKT 53x46x38**

**Technical Data**

**Material** SUS

**Surface Processing**

**Application** SENSOR BRACKET

